

SLC-17

Snap In Round Cable Twist Clamp

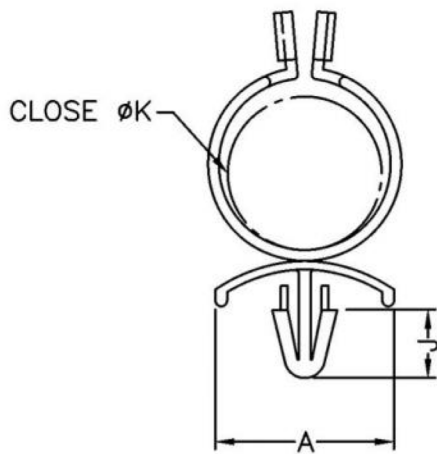
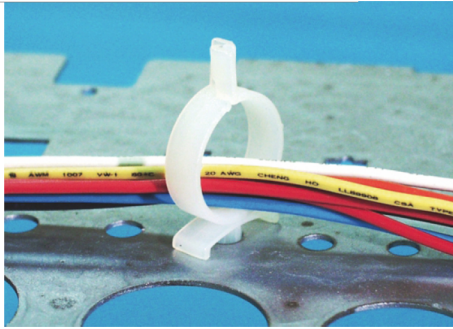

HOLE : ϕ G
THICKNESS: T

A	C	G	J	K	L	T
19.75	6.0	4.8	39.3	17.0	39.3	1.0~3.2

G	MOUNTING HOLE
T	THICKNESS

1. Shrinkage is normal
2. Measurements do not include gate which raises under 0.3mm



the **vital**
component

PART NUMBER			SLC-17	SPEC. DWG.			
TITLE							WIRE HOLDER
MATERIAL				NYLON 66(UL) 94V-2	COLOR		NATURAL
SIZE	A4	SCALE	2:1	UNIT	mm	CHECK	Z.C