

C58 HALF PITCH BOX HEADER SMT R/A



PITCH: 1.27mm * 1.27mm

SPECIFICATIONS

Material

Insulator : LCP, glass reinforced, rated UL 94V-0

Contact : Phosphor Bronze

Electrical

Current Rating : 1 Amp

Contact Resistance : 30 mΩ max.

Insulation Resistance : 1000 MΩ min.

Dielectric Withstanding Voltage : 250V AC for 1minute

Operating Temperature : -40°C to +105°C

► Mating Suggestion : B36, B37 series.

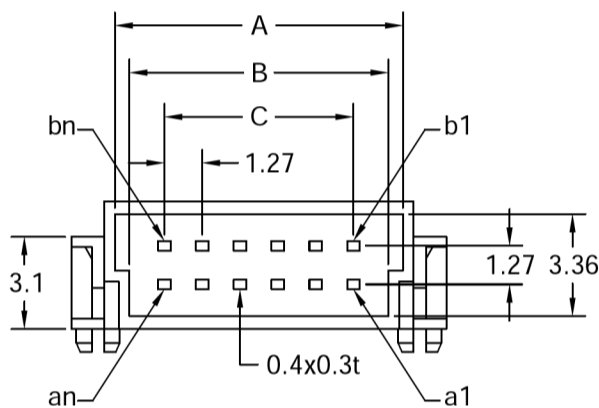
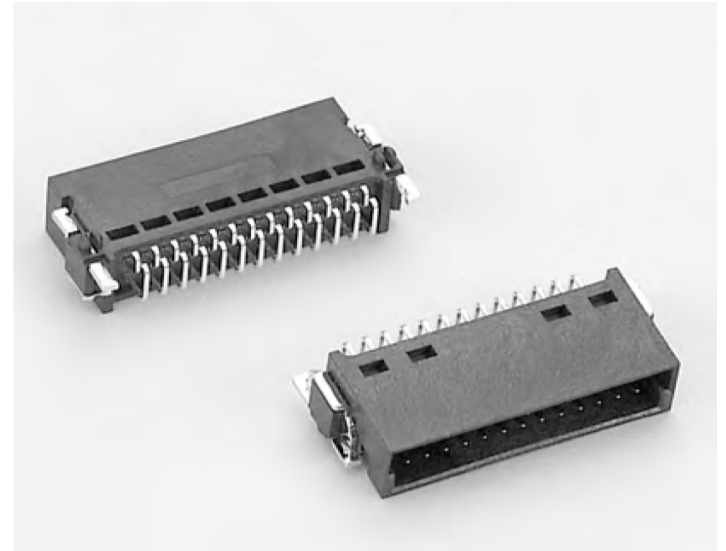

POSITION	A	B	C	D	E	F
6	5.87	4.89	2.54	8.79	6.59	6.96
8	7.14	6.16	3.81	10.06	7.86	8.23
10	8.41	7.43	5.08	11.33	9.13	9.50
12	9.68	8.70	6.35	12.60	10.40	10.77
14	10.95	9.97	7.62	13.87	11.67	12.04
16	12.22	11.24	8.89	15.14	12.94	13.31
20	14.76	13.78	11.43	17.68	15.48	15.85
22	16.03	15.05	12.70	18.95	16.75	17.12
26	18.57	17.59	15.24	21.49	19.29	19.66
30	21.11	20.13	17.78	24.03	21.83	22.20
34	23.65	22.67	20.32	26.57	24.37	24.74
40	27.46	26.48	24.13	30.38	28.18	28.55
44	30.00	29.02	26.67	32.92	30.72	31.09
50	33.81	32.83	30.48	36.73	34.53	34.90
60	40.16	39.18	36.83	43.08	40.88	41.25
68	45.24	44.26	41.91	48.16	45.96	46.33
80	52.86	51.88	49.53	55.78	53.58	53.95

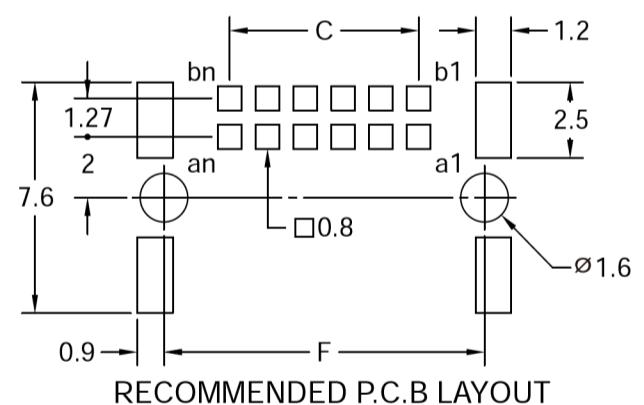
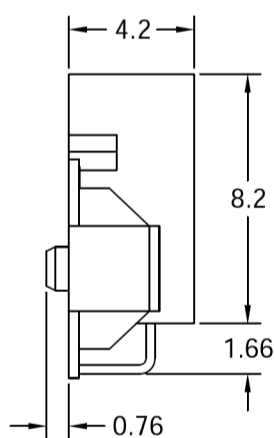
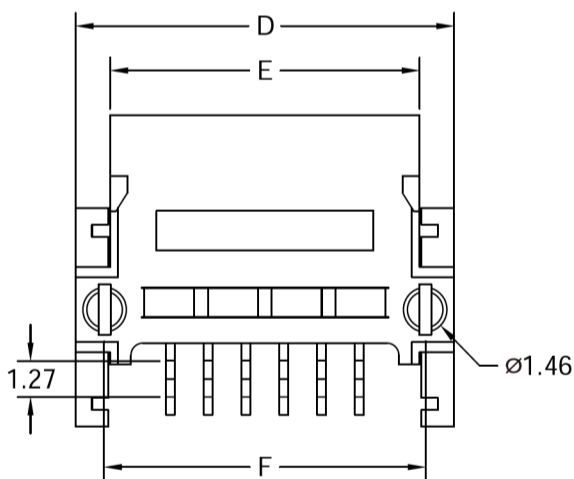

How to order: C58 - 1 - 2 - 3 - 4 - 5 - G(RoHS)

1.NO. OF CONTACT	2.CONTACT MATERIAL	3.CONTACT PLATING	4.PACKAGING	5.INSULATOR COLOR
06 08 10 12 14 16 20 22 26 30 34 40 44 50 60 68 80	B: PHOSPHOR BRONZE	S: SELECTIVE	B: TUBE W/O PAD D: TAPE & REEL W/O PAD	1. BLACK

