

MOUNT FOR FLK-SMD-7-xxx-X

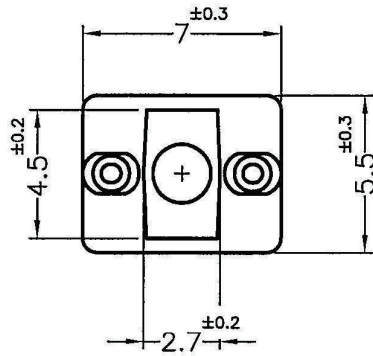

- NOTE: 1. SHRINKING IS NORMAL STATUS.  
 2. MADE OF EQUIVALENT MATERIAL.  
 3. THE COLOR BATCH TEST REPORT IS ONLY FOR FIRST LOT TEST.

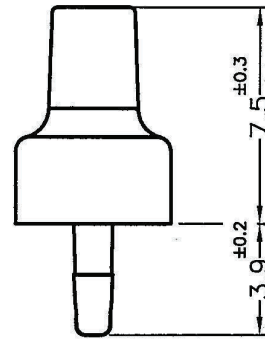
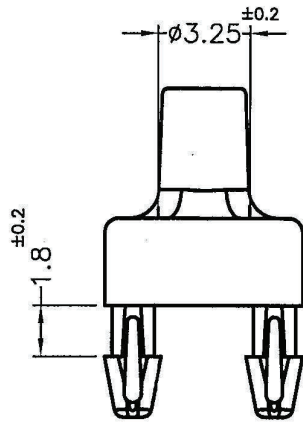
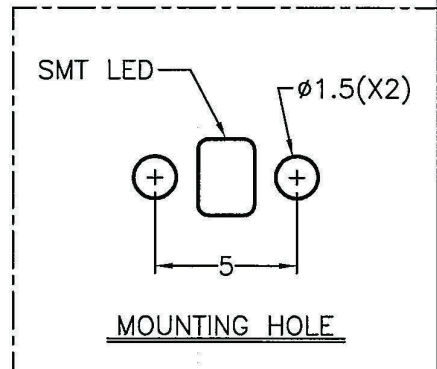

TOBY ELECTRONICS LTD  
 toby.co.uk | sales@toby.co.uk

PROPRIETARY AND CONFIDENTIAL THIS DRAWING IS THE SOLE PROPERTY OF TOBY ELECTRONICS MANUFACTURER. ANY REPRODUCTION IN PART OR AS A WHOLE WITHOUT THE WRITTEN PERMISSION OF TOBY ELECTRONICS MANUFACTURER IS PROHIBITED  DO NOT SCALE DRAWING	DATE	2007.05.08	TITLE	OPTICAL FIBER MOUNT		DWG. NO.	PART NO.				
	DRAWN	JOHNNY	MATERIAL	NYLON 66 UL94V-2		PMR-3	PMR-3				
	CHECKED	林祺翔	COLOR	BLACK	FINISH	BLACK	SIZE	A4	SPEC. DWG	REV	B
	APPROVED		UNLESS OTHERWISE SPECIFIED TOLERANCE: SEE ABOVE		SCALE: 4:1	UNIT	mm	SHEET 1 OF 1			

**FLEX FIBRE FOR FLK-xxx-xxx-X**

REVISIONS			
REV	DESCRIPTION	DATE	BY

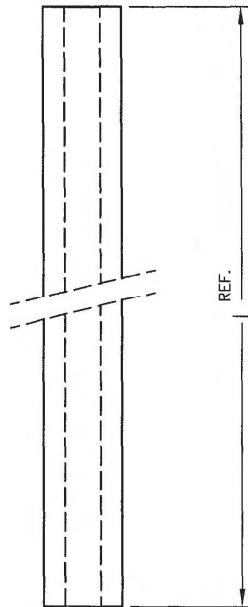
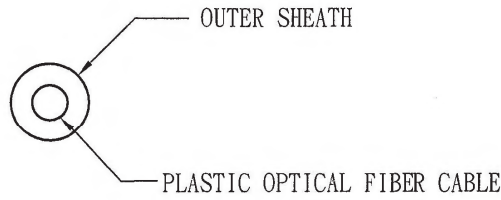

PART NO.	L=MM
FLB-3BK-	XX mm

	DIM	MATERIAL
OUTER SHEATH	$\phi 2.2^{\pm 0.07}$	PE/BLACK
FIBER TYPE CORE	$\phi 1.0^{\pm 0.2}$	POLYMETHY1 METHACRYLATE(PMMA)
FIBER TYPE CLAD		FLUORINATED POLYMER

NOTE : TRIMMED BY HAND, IT MIGHT NOT BE SMOOTH.

<b>TOBY ELECTRONICS LTD</b>				TITLE		SPEC. DWG.	
				OPTICAL FIBER LINE		DATE	
sales@toby.co.uk   toby.co.uk				CORE MATERIAL		DRAWN	
				SEE ABOVE		HANK	
PART NUMBER FLB-3BK-XX				DRAWING NUMBER FLB-3BK-XX		CHECK	
				JACKET MATERIAL		薛梅	
SIZE A4		SCALE 5:1		UNLESS OTHERWISE SPECIFIED TOLERANCE		APPROVED	
UNIT mm		REV A		SEE ABOVE		Kang	

**Plastic Optical Fiber Simplex OD2.2**



**FLB-3BK-xx: Specifications**

Simplex Cord

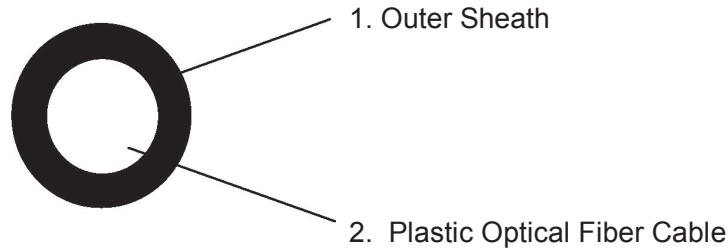

Fiber types	Core	Polymethyl Methacrylate (PMMA)
	Clad	Fluorinated Polymer
Diameter,mm		1.0mm± 0.06mm
Attenuation at 650nm*		0.2 dB/m
Outer diameter ,mm		2.2mm± 0.1mm
Outer sheath		PE
Sheath Color		BLACK
Numerical Aperture	N/A	0.5
Fiber Minimum Bend Radius		> 25mm
Tensile Strength (YIELD POINT)		64N
Cable Length		5.25Km
Cable weight		Approx. 23kg
Storage, installation, operating temperature		-20~+70°C

\*Attenuation losses may be effected on cut lengths.

**TOBY ELECTRONICS LTD**

sales@toby.co.uk | toby.co.uk

DIM.	TOL
5mm DOWN	±0.2
5~20mm	±0.3
20~40mm	±0.4
40~60mm	±0.5
60~100mm	±0.8
100mm UP	±1.0

### LENS FOR FLK-xxx-xxx-X

REVISIONS			
REV	DESCRIPTION	DATE	BY



www.toby.co.uk

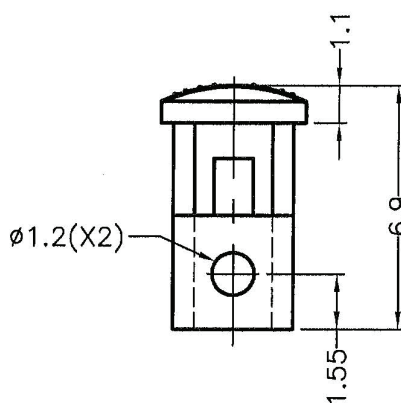
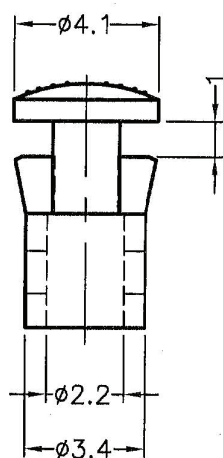
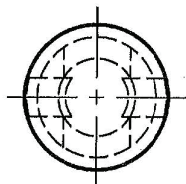

HOLE IN CHASSIS  $\phi 3.5\text{mm}$   
CHASSIS THICKNESS 1.0mm

NOTE: All measurement does not include gate which raises under 0.3mm.

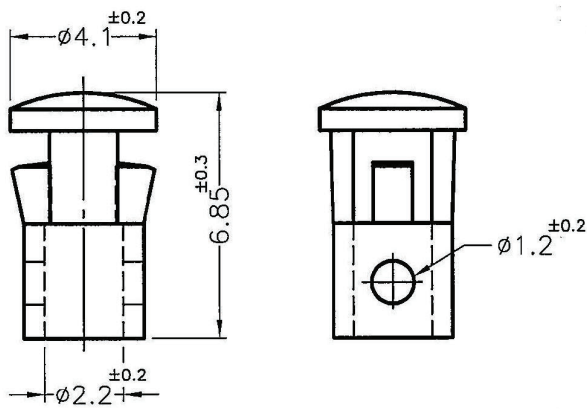
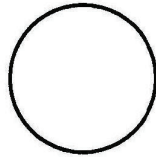

<p>TOBY ELECTRONICS LTD toby.co.uk   sales@toby.co.uk</p>				TITLE	LED CAP	SPEC. DWG	
				MATERIAL	PC UL94V-2	DATE	2004.01.16
				FINISH	BRIGHT	DRAWN	S.J.C.
				COLOR	NATURAL	CHECK	
PART NUMBER	LEU-1	DRAWING NUMBER	LEU-1	UNLESS OTHERWISE SPECIFIED TOLERANCE		APPROVED	
SIZE	A4	SCALE	5:1	UNIT	mm	REV	A
				SEE ABOVE			



HOLE IN CHASSIS  $\phi 3.5\text{mm}$   
THICKNESS 0.8mm

NOTE: 1. SHRINKING IS NORMAL STATUS.  
2. MADE OF EQUIVALENT MATERIAL.

TOBY ELECTRONICS LTD  
toby.co.uk | sales@toby.co.uk

PROPRIETARY AND CONFIDENTIAL THIS DRAWING IS THE SOLE PROPERTY OF TOBY ELECTRONICS MANUFACTURER. ANY REPRODUCTION IN PART OR AS A WHOLE WITHOUT THE WRITTEN PERMISSION OF TOBY ELECTRONICS MANUFACTURER IS PROHIBITED  DO NOT SCALE DRAWING	DATE	2006.08.09	TITLE	LED CAP	DWG. NO.	LEU-2	PART NO.	LEU-2	
	DRAWN	LEEYA	MATERIAL	PC UL94V-2	SIZE	A4	SPEC. DWG	REV	B
	CHECKED		COLOR	NATURAL	FINISH	MATTE	SCALE: 5:1	UNIT	mm
	APPROVED		UNLESS OTHERWISE SPECIFIED TOLERANCE:	SEE ABOVE		SHEET 1 OF 1			