

$\phi 1.2\text{min} * 4$
 $\phi 1.1\text{min} * 1$
 PCB MOUNTING HOLE

TOBY ELECTRONICS LTD
 sales@toby.co.uk | toby.co.uk

ITEM NO.	11-P225-R	圖號	. \MCX\11-P225-ROHS		版次	A 版
PLATING	NGT	日期	2006 年 03 月 21 日		製圖	Elva
描述	MCX RIGHT ANGLE PCB MOUNT	單位	mm	比例	5.8:1	設計
DESCRIPTION	JACK RECEPTACLE	公差	0-0.5mm ± 0.10mm	0.5-8mm ± 0.20mm	30-120mm ± 0.50mm	認定
						APPROVED

NO	DESCRIPTION	Q'TY	ITEM NO.	MATERIAL	PLATING
1	BODY 1	1	11-P225-ROHS	BRASS	NICKEL 100μ"MIN.
2	BODY 2	1	11-P2252-ROHS	BRASS	NICKEL 100μ"MIN.
3	DIELECTRIC 1	1	T-030016	PTFE	-
4	DIELECTRIC 2	1	T-030017	PTFE	-
5	CENTER PIN	1	11-P225	BERYLLIUM COPPER	GOLD 10μ"MIN.

NGT: 1st N is Nickel for body. 2nd G is Gold for pin.
 3rd T is PTFE for insulation.

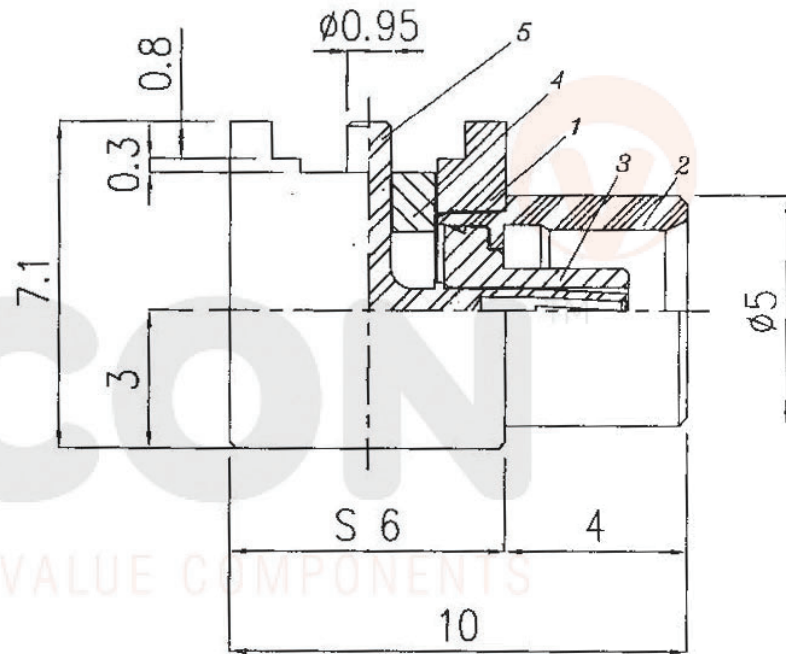
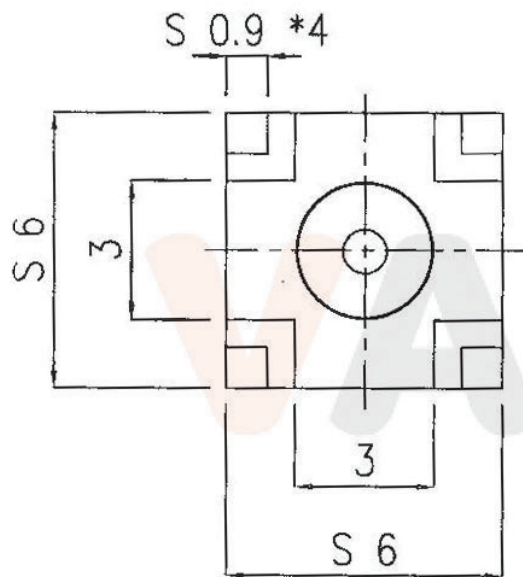

TOBY ELECTRONICS LTD
sales@toby.co.uk | toby.co.uk

ITEM NO.	11-P2251-R	圖號 DRAWING NO.	.MCX\11-P2251-ROHS			版次 EDITION	A 版
PLATING	NGT	日期 DATE	2006 年 03 月 16 日			製圖 DRAWER	Elva
DESCRIPTION	MCX RIGHT ANGLE PCB MOUNT JACK RECEPTACLE	單位 UNIT	mm	比例 SCALE	6.5:1	設計 DESIGN	
		公差 TOLERANCE	0-0.5mm ± 0.10mm	0.5-8mm ± 0.20mm		調定 CHECKED	
			8-30mm ± 0.40mm	30-120mm ± 0.50mm		APPROVED	

NO	DESCRIPTION	QTY	ITEM NO.	MATERIAL	PLATING
1	BODY 1	1	11-P2251-ROHS	BRASS	NICEKL 3-5μ" MIN.
2	BODY 2	1	11-P2251-ROHS	BRASS	NICEKL 3-5μ" MIN.
3	DIELECTRIC 1	1	T-030016	PTFE	-
4	DIELECTRIC 2	1	T-030017	PTFE	-
5	CENTER PIN	1	11-P2251	BERYLLIUM COPPER	GOLD 10μ" MIN.

NGT: 1st N is Nickel for body. 2nd G is Gold for pin.
3rd T is PTFE for insulation.