

DIM.	TOL
5mm DOWN	±0.2
5~20mm	±0.3
20~40mm	±0.4
40~60mm	±0.5
60~100mm	±0.8
100mm UP	±1.0

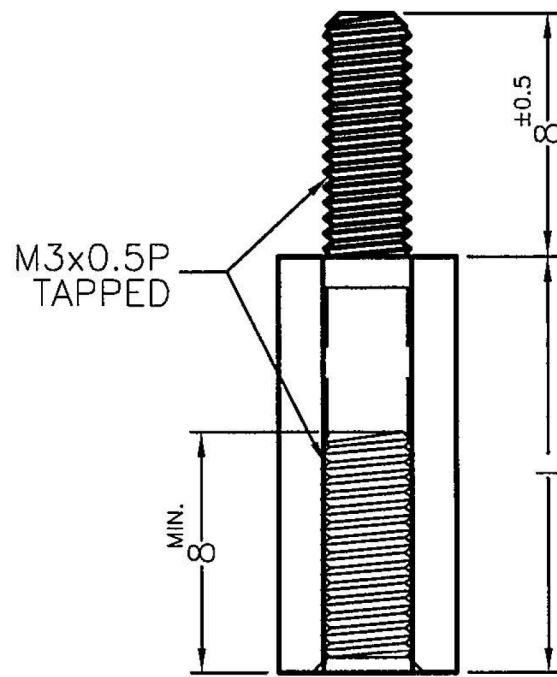
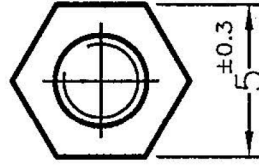

PART NO.	L
TPS-10	10.0
TPS-12	12.0
TPS-13	13.0
TPS-15	15.0
TPS-18	18.0
TPS-20	20.0
TPS-25	25.0

NOTE: 1. SOME SLIGHT NYLON BURRS REMAINED INSIDE THE THREAD HOLE IS A NORMAL PHENOMENON.

2. MADE OF EQUIVALENT MATERIAL.

Toby Electronics Ltd
www.toby.co.uk | sales@toby.co.uk

	DATE 2006.11.13	TITLE THREADED SPACER	DWG. NO. TPS-H	PART NO. SEE ABOVE	
	DRAWN BUNNY	MATERIAL NYLON 66 UL94V-2			
	CHECKED 林祺翔	COLOR NATURAL	FINISH	SIZE A4	SPEC. DWG
	APPROVED Kang	UNLESS OTHERWISE SPECIFIED TOLERANCE: SEE ABOVE		SCALE: 3:1	UNIT mm
DO NOT SCALE DRAWING				REV B	
				SHEET 1 OF 1	

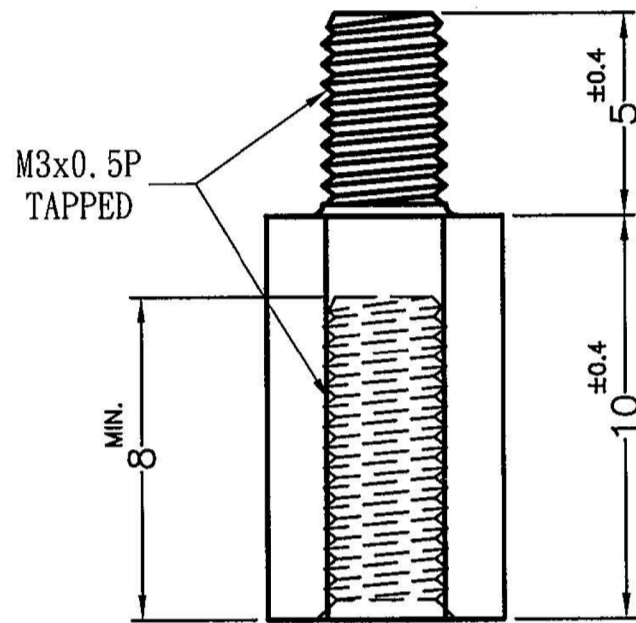
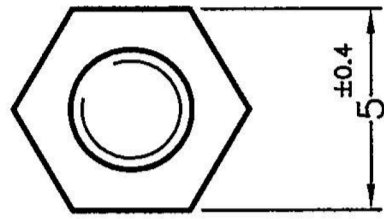

PART NO.	MATERIAL	COLOR
TPS-10S	NYLON 66 UL94V-2	NATURAL

NOTE:1. SHRINKING IS NORMAL STATUS.

2. MADE OF EQUIVALENT MATERIAL.

Toby Electronics Ltd
 www.toby.co.uk | sales@toby.co.uk

	DATE	2015.02.02	TITLE	THREADED SPACER	DWG. NO.	TPS-10S	PART NO.	SEE ABOVE	
	DRAWN	LUKE	MATERIAL	SEE ABOVE	SIZE	A4	SPEC. DWG	REV	B
	CHECKED	林祺翔	COLOR	SEE ABOVE	FINISH				
	APPROVED	Kang	UNLESS OTHERWISE SPECIFIED TOLERANCE: SEE ABOVE		SCALE:	4:1	UNIT	mm	SHEET 1 OF 1
DO NOT SCALE DRAWING									