

DIM	TOL
5mm DOWN	±0.2
5~20mm	±0.3
20~40mm	±0.4
40~60mm	±0.5
60~100mm	±0.8
100mm UP	±1.0

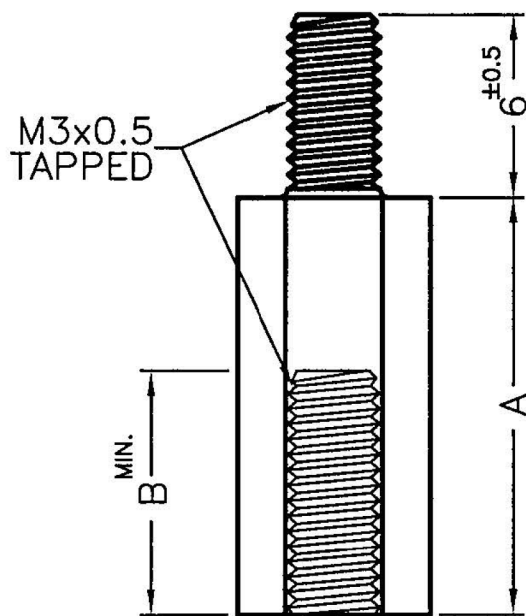
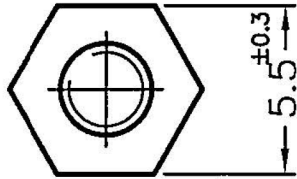

PART NO.	A	B
TP-4	4.0	3.0
TP-5	5.0	3.0
TP-6	6.0	4.0
TP-7	7.0	5.0
TP-7.5	7.5	5.0
TP-8	8.0	6.0
TP-8.5	8.5	6.0
TP-9	9.0	6.0
TP-9.5	9.5	6.0
TP-10	10.0	6.0
TP-10.5	10.5	6.0
TP-10.8L	10.8	6.0
TP-11	11.0	6.0
TP-12	12.7	6.0
TP-12A	12.0	6.0
TP-13	13.0	6.0
TP-14	14.0	6.0
TP-15	15.0	6.0
TP-15.5	15.5	6.0
TP-16	16.0	6.0
TP-16.5	16.5	6.0
TP-17	17.0	6.0

PART NO.	A	B
TP-18	18.0	6.0
TP-18.5	18.5	6.0
TP-19	19.0	6.0
TP-20	20.0	8.0
TP-21	21.0	6.0
TP-22	22.0	6.0
TP-24.5	24.5	6.0
TP-25	25.0	6.0
TP-27	27.0	6.0
TP-28	28.0	6.0
TP-28.5	28.5	6.0
TP-30	30.0	8.0
TP-33	33.0	6.0
TP-34.5	34.5	6.0
TP-35	35.0	6.0
TP-36	36.0	6.0
TP-37	37.0	6.0
TP-40	40.0	6.0
TP-45	45.0	6.0
TP-53.5	53.5	6.0

NOTE: 1. INNER THREAD WAS DONE BY 2ND PROCESS TAPING.  
 SOME SLIGHT NYLON BURRS REMAINED INSIDE THE THREAD HOLE IS A NORMAL PHENOMENON.  
 2. MADE OF EQUIVALENT MATERIAL.

Toby Electronics Ltd  
 www.toby.co.uk | sales@toby.co.uk

	DATE 2004.01.07	TITLE THREADED SPACER	DWG. NO. TP-H	PART NO. SEE ABOVE	
	DRAWN JASON	MATERIAL NYLON 66 UL94V-2			
	CHECKED 林祺翔	COLOR NATURAL	FINISH	SIZE A4	SPEC. DWG
	APPROVED <i>Kan G</i>	UNLESS OTHERWISE SPECIFIED TOLERANCE: SEE ABOVE		SCALE: NONE	UNIT mm
DO NOT SCALE DRAWING				REV Q	
				SHEET 1 OF 1	