

DIM.	TOL.
5mm DOWN.	±0.2
5~20mm	±0.3
20~40mm	±0.4
40~60mm	±0.5
60~100mm	±0.8
100mm UP.	±1.0

REVISIONS			
REV	DESCRIPTION	DATE	BY

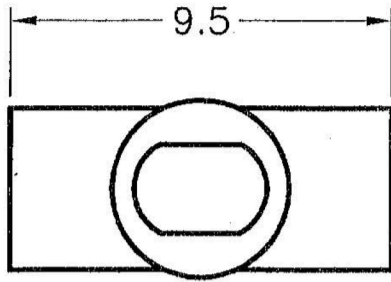

HOLE IN P.C.B ϕ 2.5
P.C.B THICKNESS 1.6

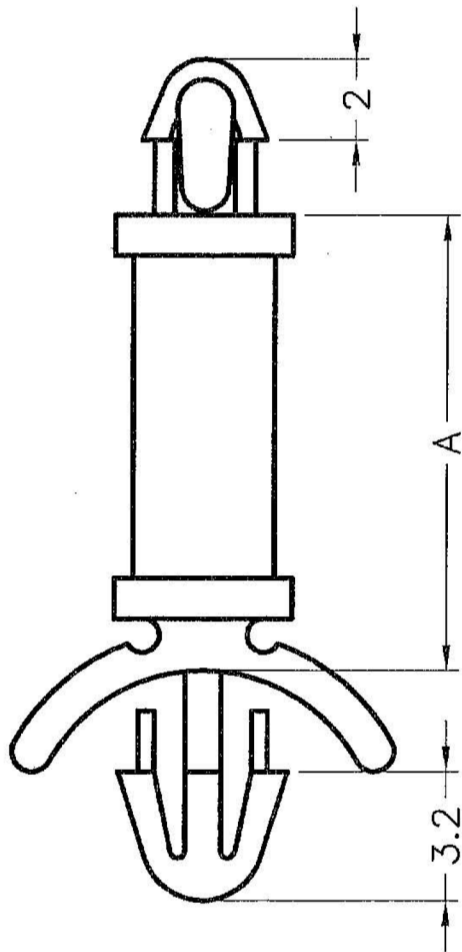

HOLE IN CHASSIS: ϕ 3~ ϕ 3.2
CHASSIS THICKNESS: 0.8~2.0

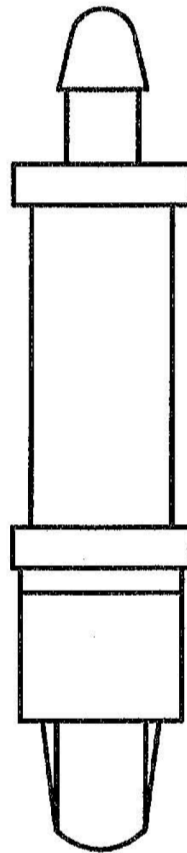

PART NO.	A
LCMD-3.2	3.2
LCMD-4.8	4.8
LCMD-6.4	6.4
LCMD-7.9	7.9
LCMD-9.5	9.5
LCMD-11.1	11.1
LCMD-12.7	12.7
LCMD-14.3	14.3
LCMD-17	17.0
LCMD-15.9	15.9

NOTE: All measurement does not include gate which raises under 0.3mm.

				TITLE	SPACER SUPPORT	SPEC. DWG.	
				MATERIAL	NYLON 66 UL94V-2	DATE	2006.12.13
				FINISH		DRAWN	JOHNNY
				COLOR	NATURAL	CHECK	
PART NUMBER	SEE ABOVE	DRAWING NUMBER	LCMD-H	UNLESS OTHERWISE SPECIFIED TOLERANCE	SEE ABOVE	APPROVED	
SIZE	A4	SCALE	NONE	UNIT	mm	REV	B