

⚠ This dwg is for reference only, Actual dwg should be based on formal engineering dwg issued by Kang Yang.

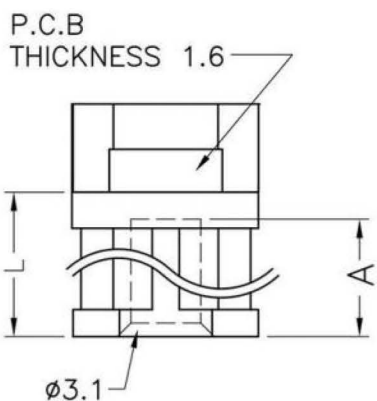

FOR M3.5 TAPPING SCREW

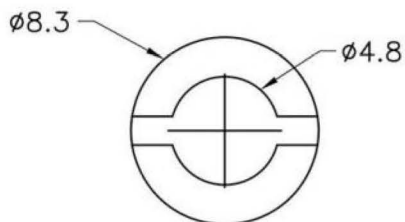
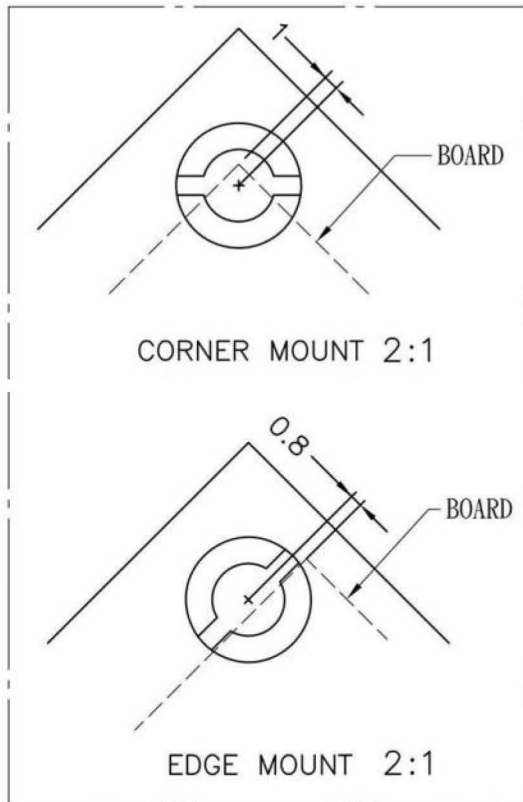

Part No.	A	L	Package
TCEH-6.4	5.2	6.4	1000
TCEH-9.5	7.9	9.5	
TCEH-12.7	7.9	12.7	
TCEH-15.9	7.9	15.9	

1.All measurement does not include gate which raises under 0.3mm.
 2.Made of equivalent material.



www.toby.co.uk

PART NUMBER		TCEH-xxx		SPEC. DWG.	
TITLE					
SPACER SUPPORT					
MATERIAL			COLOR		
NYLON 66(UL) 94V-0			NATURAL		
SIZE	SCALE	UNIT	CHECK		
A4	2:1	mm	Z.C		