

NO : XXXXXXXX

REV.	DATE	DESCRIPTION
A	09/01/106	RELEASED
B	XX/XX/XX	
C	XX/XX/XX	

**RoHS COMPLIANT**

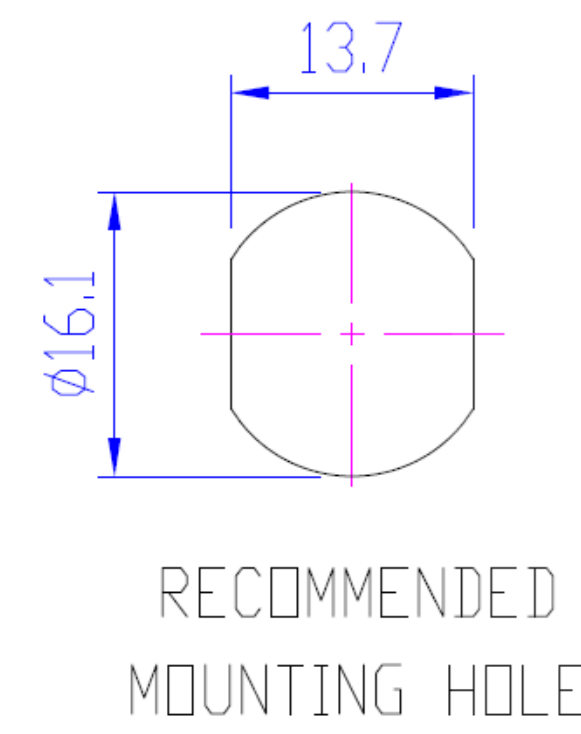
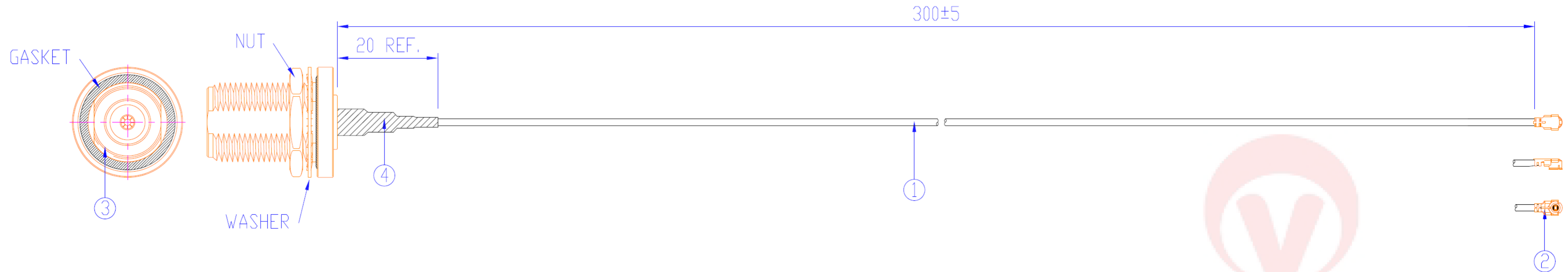

- MATERIAL LIST**
1. RF COAXIAL CABLE  $\phi$ 1.32mm; JACKET COLOR : GRAY (x1)
  2. MICRO COAXIAL CONNECTOR (I-PEX MHF SERIES) (x1)
  3. N SERIES (CRIMP ATTACHMENT FOR FLEXIBLE CABLE) STRAIGHT BULKHEAD JACK (SM7361DS534) (x1)
  4. HEAT SHRINK TUBE ( $\phi$ 5.0x20mm) (x1)

- NOTE FOR INSPECTION :**
- \*. SURFACE (NO BROKEN IN WIRE, NO OXIDIZE IN CONNECTOR, NO EXPOSE IN ASSEMBLED POINT, NO BROKEN IN CORD, NO TAKE OFF WHEN PULLING FOR SHRINK TUBE, TIN SHOULD BE UNIFORM.)
  - \*. SIZE (LENGTH OF OVERALL, STRIP, INSULATOR, BRAID & SHRINK TUBE.)
  - \*. DIAMETER OF WIRE
  - \*. SHORT TESTING

- REMARK :**
- \*. RF CABLE TYPE  $\phi$ 1.32mm
  - \*. OVERALL CABLE LENGTH IS ABOUT 300mm
  - \*. IMPEDANCE 50ohm
  - \*. RELATIVE DIRECTION BETWEEN CONNECTORS ARE SHOWN
  - \*. RoHS COMPLIANT
  - \*. THIS DRAWING IS FOR REFERENCE ONLY

- PACKING :**
- \*. 1 PCS/POLY BAG
  - \*. 100PCS (NOT SURE, DEPEND ON WEIGHT) PE DAMP PROOF BAG/ONE CARTION

**壓著 :**

- \*. N CONN. - CRIMPED FERRULE  
HEX CRIMP SIZE 0.128" & 0.068" (3.25mm&1.72mm)  
(套管壓著工具)

TOBY ELECTRONICS LTD www.toby.co.uk   sales@toby.co.uk		圖名 (NAME)	300mm; $\phi$ 1.32mm N BULKHEAD JACK TO I-PEX CABLE		
一般公差 TOLERANCE	UNLESS OTHERWISE SPECIFIED 2 PLACE DECIMAL 0.00 $\pm$ 0.25mm 1 PLACE DECIMAL 0.0 $\pm$ 0.35mm 0 PLACE DECIMAL 0 $\pm$ 0.50mm ANGULAR $\pm$ 15 MINUTES (0.25°)	繪圖 (DRAW)	SONG 09/01/106		
		審核 (CHK)			
投影法 PROJECTION	第三角	客戶 (CUSTOMER)			
		比例 (SCALE)	FIT	單位 (UNIT)	mm
		圖號 (NO)	TRFC-IPEX-N-F-132-300MM		