

(6.35 mm) .250" PITCH • 40 A CABLE ASSEMBLY/COMPONENTS

PESS	NO. OF POSITIONS	WIRE GAUGE	PLATING OPTION	ASSEMBLED LENGTH	END 1 OPTION	END 2 OPTION
	-02, -04, -06, -08	-10 -12	-L = 10 μ" (0.25 μm) Gold on contact, Matte Tin on tail -T = Matte Tin on tail	-"XX.XX" = Wire length in inches (152.4 mm) 06.00" min.	-SR = Single End -DR = Double End	(Available with -DR only) -NUS = Notch up, straight (Available with -DR only) -NDS = Notch down, straight

PESS
Board Mates:
PET

SPECIFICATIONS

Insulator Material:
Nylon Black
Contact Material:
Copper Alloy
Plating:
Sn or Au over
50 μ" (1.27 μm) Ni
Operating Temp Range:
-30 °C to +105 °C
Voltage Rating:
600 VAC
846 VDC
Wire:
10 or 12 AWG

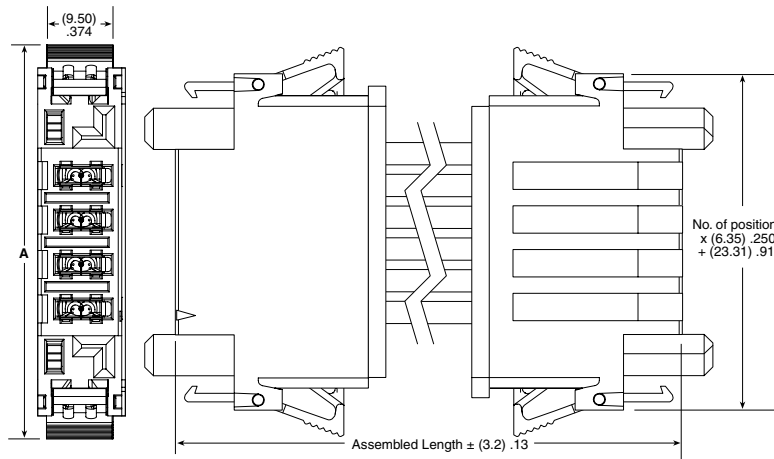

NO. OF POSITIONS	A
-02	(43.9) 1.73
-04	(56.6) 2.23
-06	(69.3) 2.73
-08	(82.0) 3.23

PESS/PET	
WIRE GAUGE	CURRENT RATING (PER PIN)
10 AWG	34.5 A
12 AWG	29.7 A

1 PIN POWERED

IP56	POSITIONS PER ROW	01	LATCH	SERIES	WIRE GAUGE	PLATING OPTION
	-02, -04, -06, -08		-L = Latch	CC10R = Contact, Full Reel CC10L = Contact, Loose	-1012 = 10 to 12 AWG	-L = 10 μ" (0.25 μm) Gold on contact, Matte Tin on tail -T = Matte Tin on tail

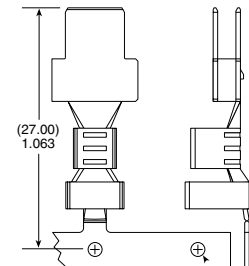
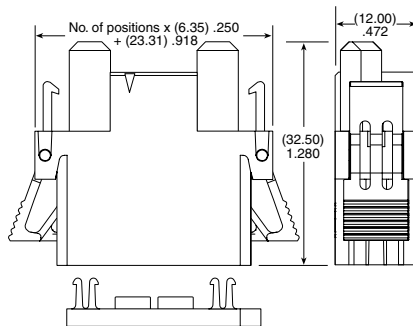
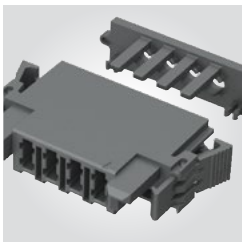

TOOLING

Hand Tool: CAT-HT-310-1012-14
Mini Applicator: CAT-MC-310-1012-XX-02

Note:
Some lengths, styles and options are non-standard, non-returnable