

Dept	Qty
DC	1
ED	1
IE	1
ISO	1
PD	1
R&D	1
SD	1
QA	1
QC	1
QE	1

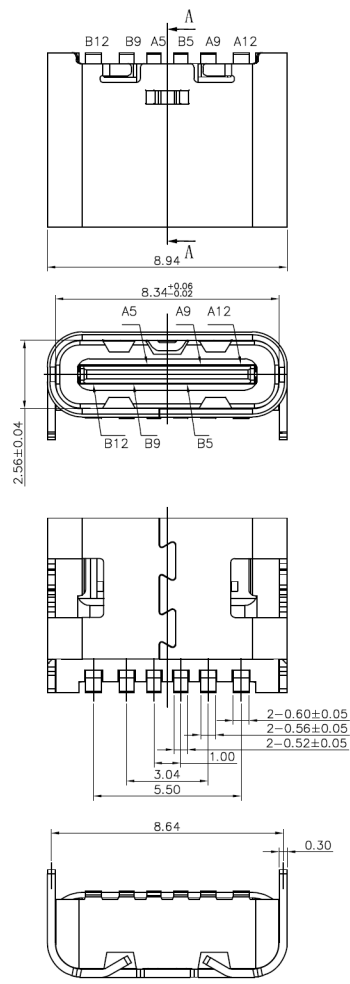

Pin assignments

A5	CC1	B12	GND
A9	VBUS	B9	VBUS
A12	GND	B5	CC2
Pin	Signal name	Pin	Signal name

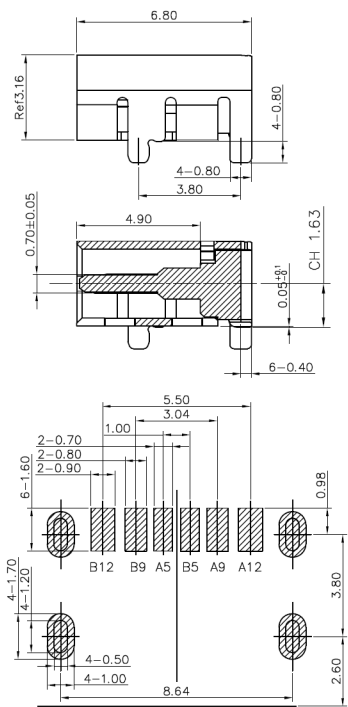

Recommend PCB layout
(Tolerance:±0.05)



(Series Image-Reference Only)

REV.	DESCRIPTION	DRAWN	CHECKED	APPROVED
A	NEW RELEASE	JLZ 01/18/21'		

NOTE:

- Material specification:
 - Housing:High temperature resistant plastic,UL94 V-0.
 - Contacts:Copper alloy
 - Shell: Stainless steel
- Electrical performance:
 - Current rating:5.0A
Voltage rating:20.0V
 - LLCR:
 - Vbus & Gnd pins and other pins: 40mΩ/Pin Max.
Shield: 50mΩ/Max.
LLCR Max. Change of all pins: 10mΩ.
 - Insulation resistance: 100MΩ Min
 - Dielectric withstand voltage,AC 100V for 1 minute.
- Environmental performance:
 - Operating temperature: -25°C~+85°C.
- Ir reflow:
 - The peak temperature on the board shall Be maintained for 10 seconds at 260°C.
- Ordering Information:

USBC-06PO-HZ-SMT = supplied on cut tape,supplied without leader

USBC-06PO-HZ-SMT-FR = supplied on Full Reel, in Full Reel increments only



GENERAL TOLERANCE		ANGLE TOLERANCE		PROJECTION		TITLE	USB Type-C 6P Female Horizontal SMT Type L=6.8mm Centre-H=0.05mm
X.	±0.60	X.	±5°	UNITS	mm		
.X	±0.38	.X	±3°	SHEET SIZE	A4	SERIES	
.XX	±0.25	.XX	±2°				
DRAWING TYPE		CUSTOMER		Toby Electronics Ltd		 www.toby.co.uk	
SCALE	1:1	SHEET	1 OF 1	W: www.toby.co.uk			
DRAWING NO.				E: sales@toby.co.uk T: +44 (0)1295 271777			