

NOTES:

1. STANDARD PART SET UP AS ASP FOR VITA 57.4.
2. Ⓢ REPRESENTS A CRITICAL DIMENSION.
3. MINIMUM PUSHOUT FORCE: 0.50 LBS.
4. ATTACH LABEL "SEAX-0001" TO EACH TAPE & REEL PACKAGE.
5. DIMENSION C8 MUST BE MEASURED USING INSPECTION FIXTURE AT-1817-836-1, USE CO-AU-WI-2003-M FOR PROCESS.
6. MAXIMUM ROW TO ROW VARIATION .003[0.08], MEASURED FIRST & LAST POSITIONS ONLY, ALL ROW.
7. PARTS TO BE PACKAGED IN TAPE & REEL.

DO NOT SCALE FROM THIS PRINT

ANY REV MADE TO THIS PRINT MUST HAVE AN UPDATED MKT PRINT

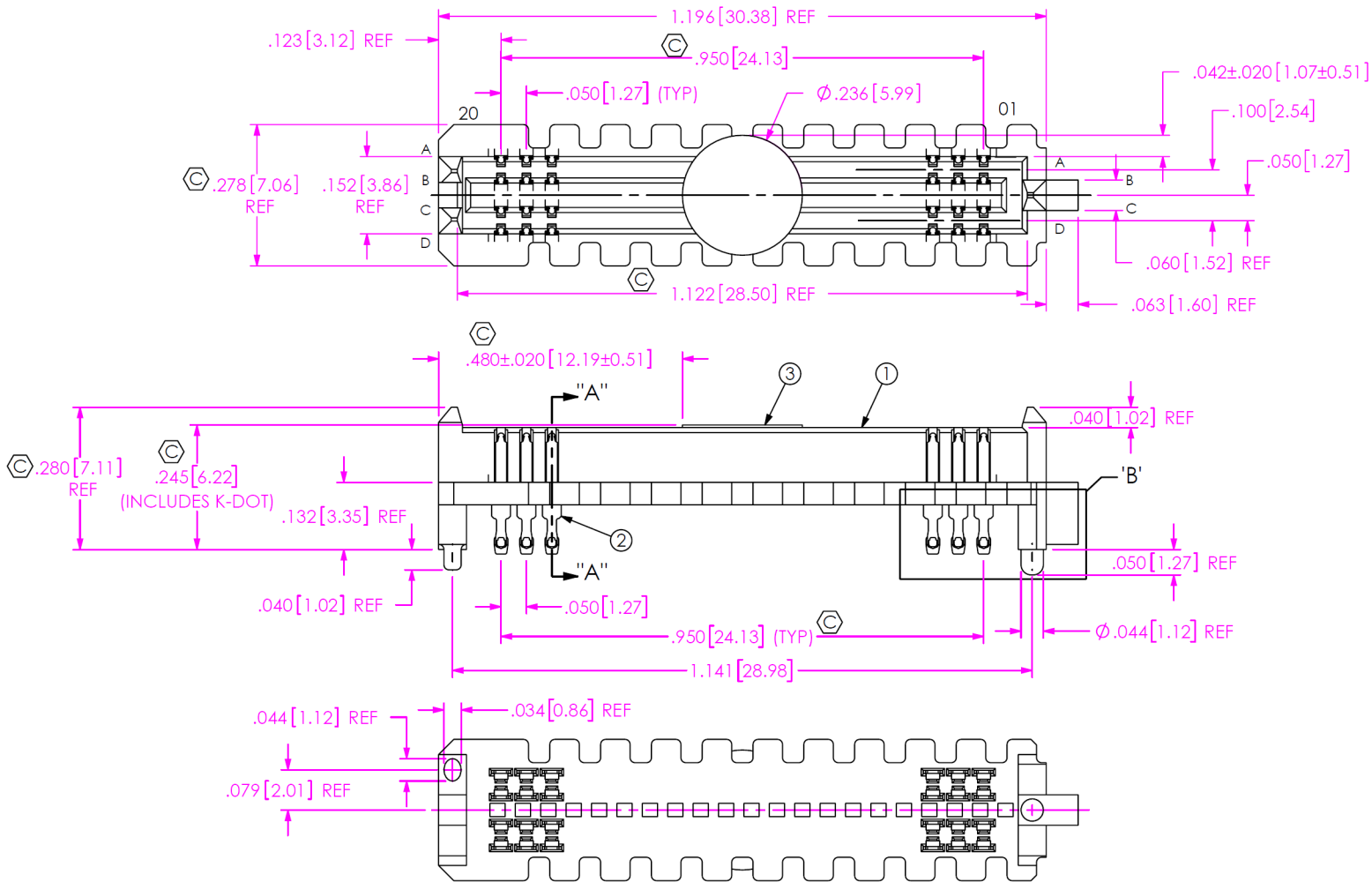
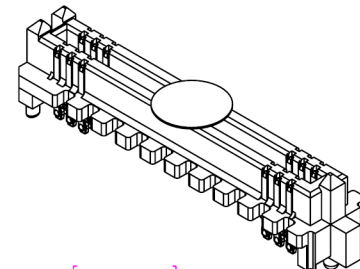

THE VITAL COMPONENT

UNLESS OTHERWISE SPECIFIED, DIMENSIONS ARE IN INCHES.

TOLERANCES ARE:

DECIMALS ANGLES
 .XX: ±.01[0.3] 2°
 .XXX: ±.005[0.13]
 .XXXX: ±.0020[0.051]

PROPRIETARY NOTE

THIS DOCUMENT CONTAINS CONFIDENTIAL AND PROPRIETARY INFORMATION AND ALL DESIGN, MANUFACTURING, REPRODUCTION, USE, PATENT RIGHTS AND SALES RIGHTS ARE EXPRESSLY RESERVED BY SAMTEC, INC. THIS DOCUMENT SHALL NOT BE DISCLOSED, IN WHOLE OR PART, TO ANY UNAUTHORIZED PERSON OR ENTITY NOR REPRODUCED, TRANSFERRED OR INCORPORATED IN ANY OTHER PROJECT IN ANY MANNER WITHOUT THE EXPRESS WRITTEN CONSENT OF SAMTEC, INC.



520 PARK EAST BLVD, NEW ALBANY, IN 47150
 PHONE: 812-944-6733 FAX: 812-948-5047
 e-Mail: info@SAMTEC.com code 55322

DO NOT SCALE DRAWING

SHEET SCALE: 1:1

PLATING:
 CONTACT AREA: .000030 GOLD OVER .000050 NICKEL
 REMAINDER: .000200 REF TIN OVER .000050 NICKEL

DESCRIPTION:
 .050 PITCH TERMINAL ARRAY ASSEMBLY

DWG. NO.
 ASP-186900-01

BY: D MOK 05/06/2015 SHEET 1 OF 3

ITEM NO.	PART NUMBER	QUANTITY	MATERIAL
1	SEAM-20-03.5-04-A	1.0000	VECTRA E130i, COLOR: BLACK
2	NEW-SUB-T-1M36-03.5-S-2	80.000	COPPER ALLOY/LEAD FREE SOLDER Ⓢ
3	K-DOT-.236-.343-.005	1.0000	POLYIMIDE FILM
4	CT-SEAM028MS	.00333	CONDUCTIVE POLYMER

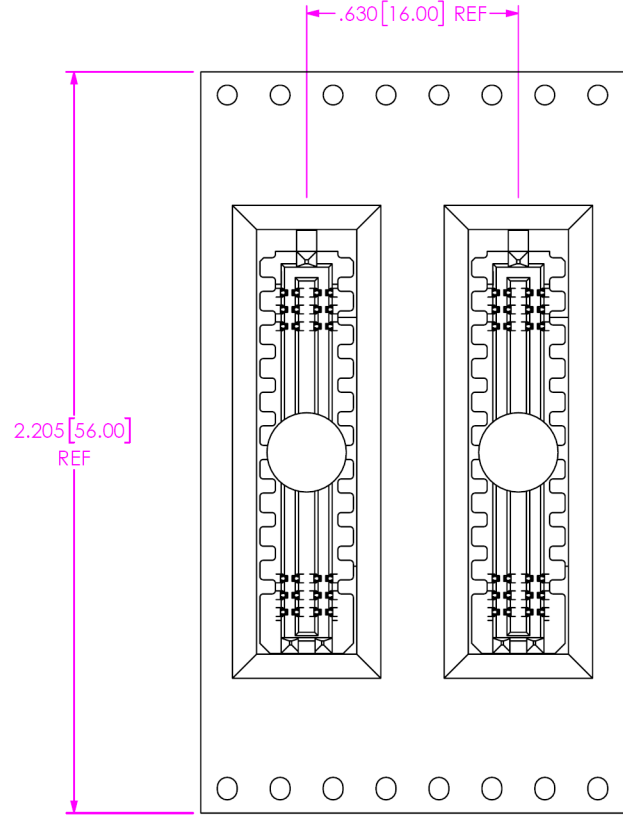
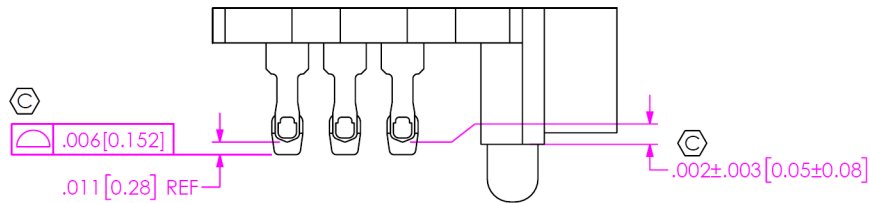
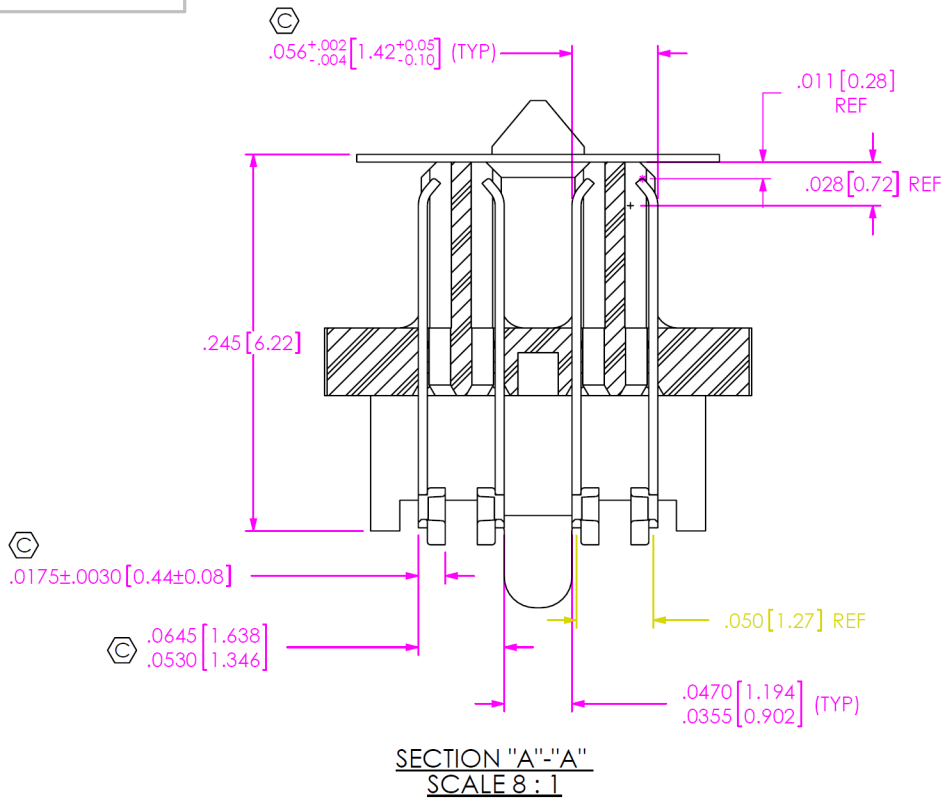

USER DIRECTION OF UN-REELING
POCKET NOT DETAILED →

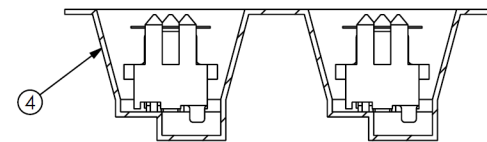

DETAIL 'B'
SCALE 6 : 1

PROPRIETARY NOTE

THIS DOCUMENT CONTAINS CONFIDENTIAL AND PROPRIETARY INFORMATION AND ALL DESIGN, MANUFACTURING, REPRODUCTION, USE, PATENT RIGHTS AND SALES RIGHTS ARE EXPRESSLY RESERVED BY SAMTEC, INC. THIS DOCUMENT SHALL NOT BE DISCLOSED, IN WHOLE OR PART, TO ANY UNAUTHORIZED PERSON OR ENTITY NOR REPRODUCED, TRANSFERRED OR INCORPORATED IN ANY OTHER PROJECT IN ANY MANNER WITHOUT THE EXPRESS WRITTEN CONSENT OF SAMTEC, INC.



520 PARK EAST BLVD, NEW ALBANY, IN 47150
PHONE: 812-944-6733 FAX: 812-948-5047
e-Mail info@SAMTEC.com code 55322

SHEET SCALE: 1:1

DESCRIPTION:
.050 PITCH TERMINAL ARRAY ASSEMBLY

DWG. NO.
ASP-186900-01

BY: D MOK 05/06/2015 SHEET 2 OF 3



CONNECTOR ASSEMBLY OUTLINE
OTHER COMPONENTS PLACED
ON PCB SHALL AVOID THIS ZONE

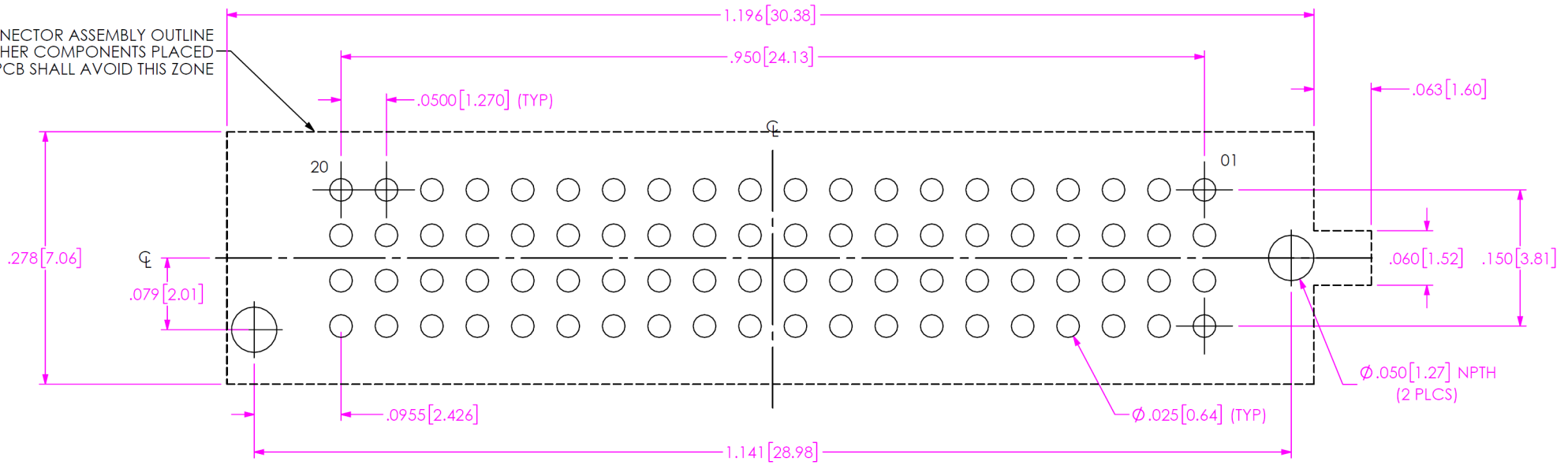

RECOMMENDED PCB LAYOUT
ALL DIMENSIONS ARE SYMMETRIC ABOUT CENTERLINE

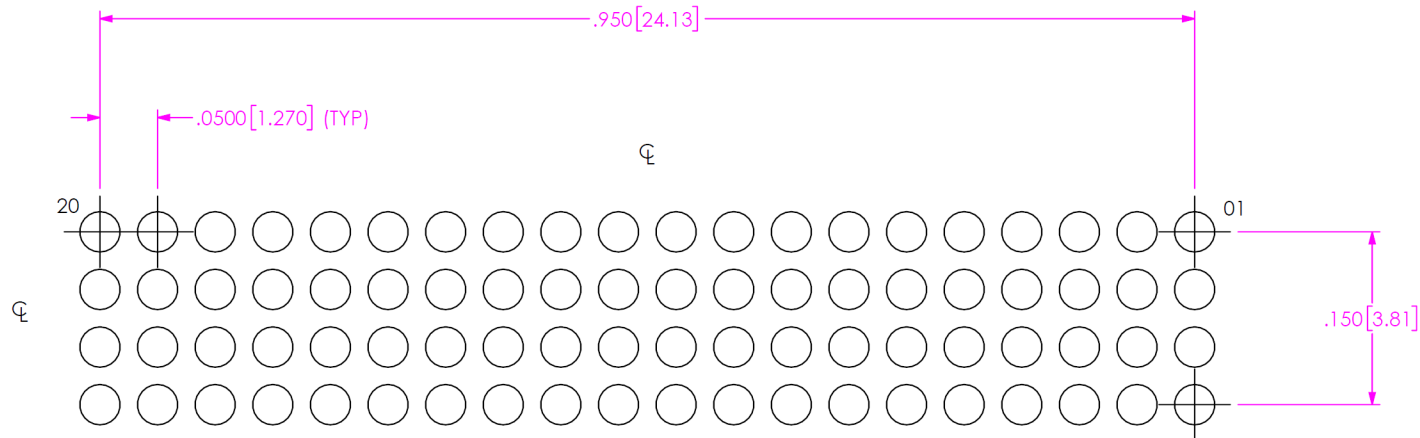

RECOMMENDED STENCIL LAYOUT
STENCIL TO BE .0060 [0.152] THICK

PROPRIETARY NOTE

THIS DOCUMENT CONTAINS CONFIDENTIAL AND PROPRIETARY INFORMATION AND ALL DESIGN, MANUFACTURING, REPRODUCTION, USE, PATENT RIGHTS AND SALES RIGHTS ARE EXPRESSLY RESERVED BY SAMTEC, INC. THIS DOCUMENT SHALL NOT BE DISCLOSED, IN WHOLE OR PART, TO ANY UNAUTHORIZED PERSON OR ENTITY NOR REPRODUCED, TRANSFERRED OR INCORPORATED IN ANY OTHER PROJECT IN ANY MANNER WITHOUT THE EXPRESS WRITTEN CONSENT OF SAMTEC, INC.



520 PARK EAST BLVD, NEW ALBANY, IN 47150
PHONE: 812-944-6733 FAX: 812-948-5047
e-Mail info@SAMTEC.com code 55322

SHEET SCALE: 6:1

DESCRIPTION:
.050 PITCH TERMINAL ARRAY ASSEMBLY

DWG. NO.
ASP-186900-01