

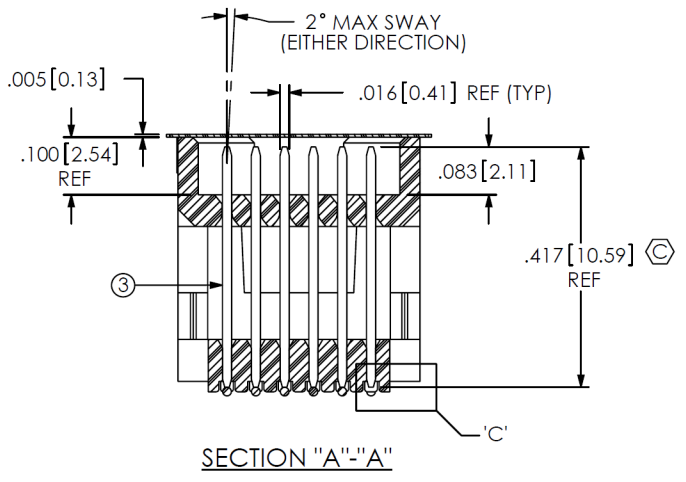

- NOTES:
 1. 6 ROW, 19 POSITION NOT AVAILABLE AS STANDARD. USE LEAD FREE SOLDER BALLS.
 2. Ⓢ REPRESENTS A CRITICAL DIMENSION.
 3. MAXIMUM BURR ALLOWANCE: .0015[0.038]
 4. MAXIMUM CUT FLASH: .010[0.25].
 5. MAXIMUM ALLOWABLE BOW: TOP/BOTTOM: .006[0.15], SIDE/SIDE: .003[0.08].
 6. PARTS TO BE PACKAGED IN TAPE & REEL. FOR QTY'S LESS THAN 125 PCS, NO TRAILER OR LEADER WILL BE SUPPLIED.

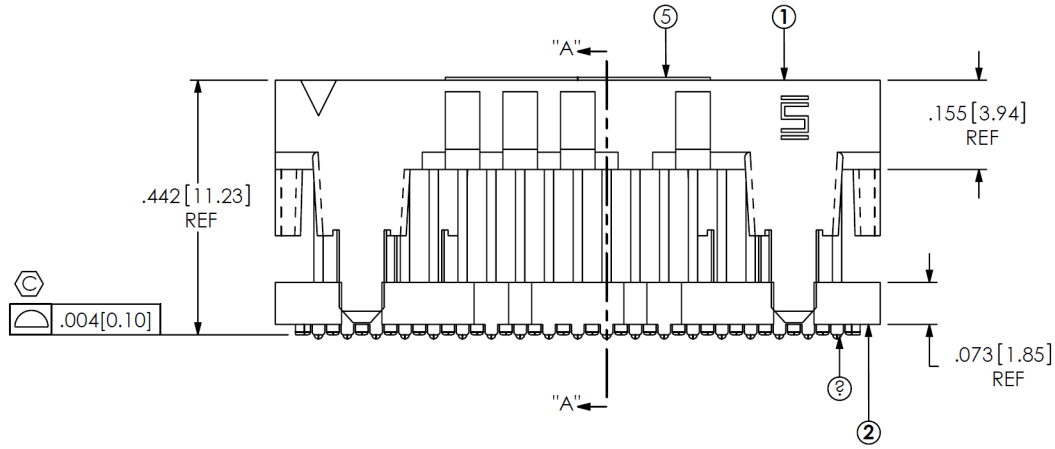
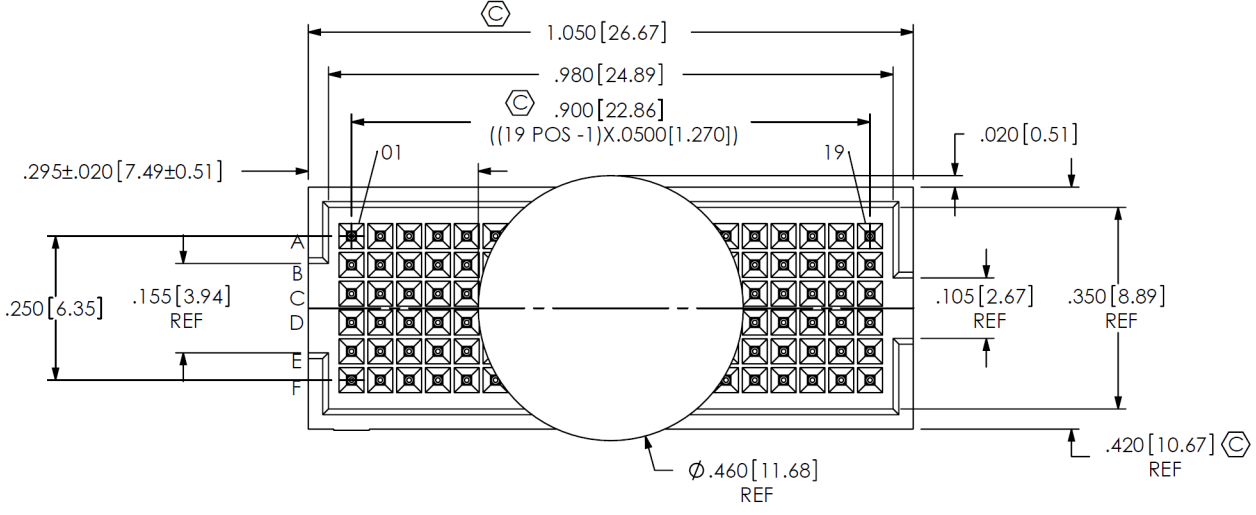
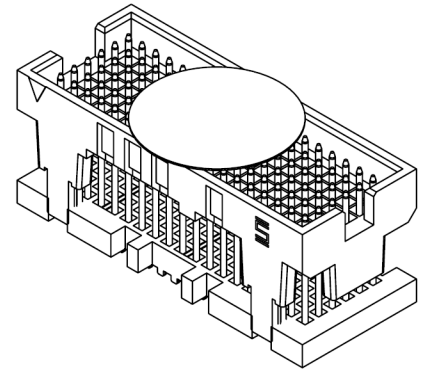

BY SIGNING THIS DOCUMENT YOU ARE ACCEPTING THE CONDITIONS SET WITHIN. YOUR REQUIREMENTS MUST BE LISTED WITHIN THIS DRAWING. WHERE NO DIRECTION FROM THE CUSTOMER IS IDENTIFIED SAMTEC'S PROCESS REQUIREMENTS WILL BE USED.

DATE: _____
 COMPANY: _____
 CUSTOMER SIGNATURE: _____
 PRINTED NAME: _____
 PHONE No: _____
 EXCEPTIONS: _____

ITEM NO.	PART NUMBER	QUANTITY	MATERIAL
1	ASP-103598-03-B	1.0000	UL 94V0, COLOR: BLACK
2	ASP-103599-01-B	1.0000	UL 94V0, COLOR: BLACK
3	T-1R27-12B-H-1	114.00	BRASS ALLOY 260, 3/4 HARD
4	SDB-030-9653	114.00	96.5%Sn/3% Ag/ .5%Cu
5	K-850-650	.89000	POLYIMIDE FILM
6	CT-ASP3112MS	.00571	CONDUCTIVE POLYMER

K

UNLESS OTHERWISE SPECIFIED, DIMENSIONS ARE IN INCHES. TOLERANCES ARE:
 DECIMALS ANGLES
 .XX: ±.01 2°
 .XXX: ±.005
 .XXXX: ±.0020

PROPRIETARY NOTE
 THIS DOCUMENT CONTAINS INFORMATION CONFIDENTIAL AND PROPRIETARY TO SAMTEC, INC. AND SHALL NOT BE REPRODUCED OR TRANSFERRED TO OTHER DOCUMENTS OR DISCLOSED TO OTHERS OR USED FOR ANY PURPOSE OTHER THAN THAT WHICH IT WAS OBTAINED WITHOUT THE EXPRESSED WRITTEN CONSENT OF SAMTEC, INC.



520 PARK EAST BLVD, NEW ALBANY, IN 47150
 PHONE: 812-944-6733 FAX: 812-948-5047
 e-Mail: info@SAMTEC.com code 55322

DO NOT SCALE DRAWING SHEET SCALE: 3:1
 PLATING:
 CONTACT AREA: .000030 GOLD OVER .000050 NICKEL
 REMAINDER: .000003 GOLD OVER .000050 NICKEL
 F:\DWG\MISC\MKTG\ASP-153860-01-MKT.SLDDRW

DESCRIPTION:
 VITA 42 (LEAD FREE) SOCKET ASSEMBLY
 DWG. NO. ASP-153860-01
 BY: J. BROWNING 03/04/2010 SHEET 1 OF 2

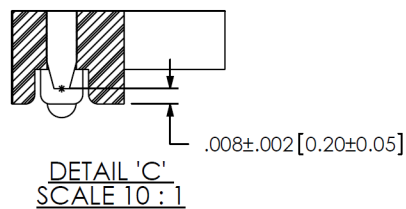
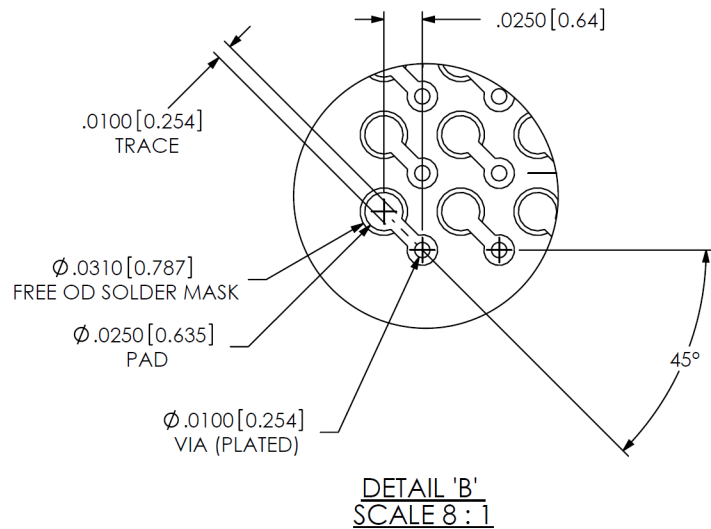
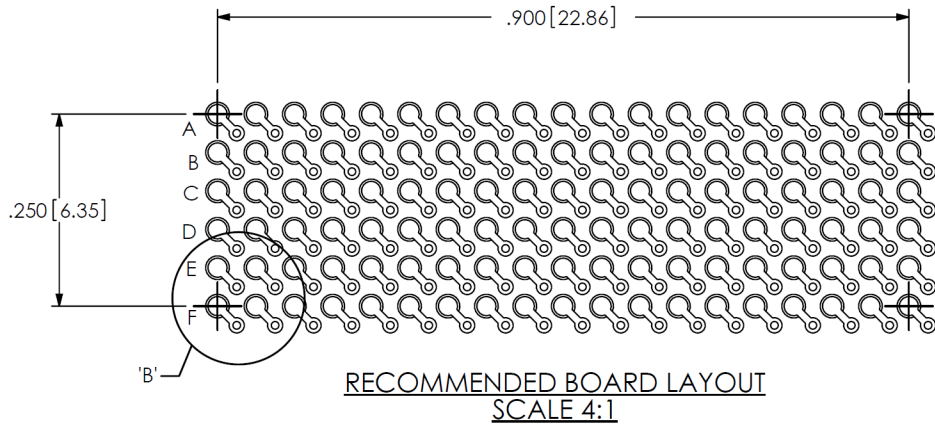

RECOMMENDED STENCIL LAYOUT
STENCIL TO BE .0060[0.152] THICK

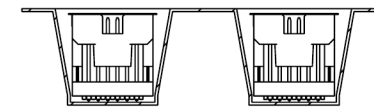
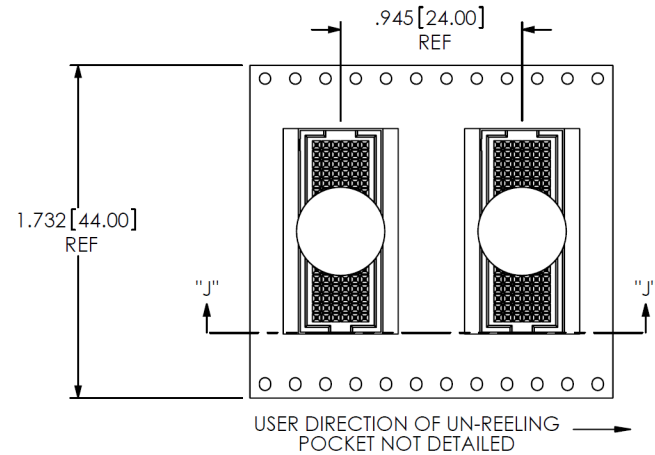
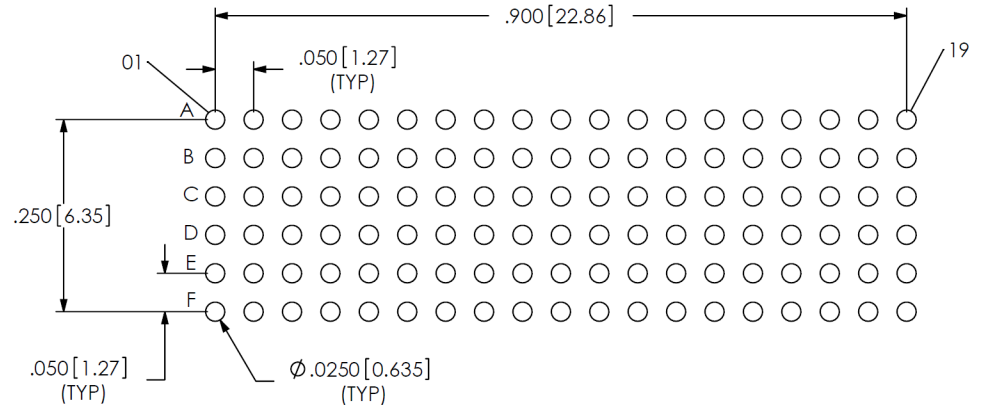

SECTION "J"-"J"
SCALE 1:1

PACKAGING VIEW
SCALE 1:1



PROPRIETARY NOTE

THIS DOCUMENT CONTAINS INFORMATION CONFIDENTIAL AND PROPRIETARY TO SAMTEC, INC. AND SHALL NOT BE REPRODUCED OR TRANSFERRED TO OTHER DOCUMENTS OR DISCLOSED TO OTHERS OR USED FOR ANY PURPOSE OTHER THAN THAT WHICH IT WAS OBTAINED WITHOUT THE EXPRESSED WRITTEN CONSENT OF SAMTEC, INC.



520 PARK EAST BLVD, NEW ALBANY, IN 47150
PHONE: 812-944-6733 FAX: 812-948-5047
e-Mail: info@SAMTEC.com code 55322

SHEET SCALE: 3:1

DESCRIPTION:
VITA 42 (LEAD FREE) SOCKET ASSEMBLY

DWG. NO. ASP-153860-01