

RECOMMENDED BOARD LAYOUT

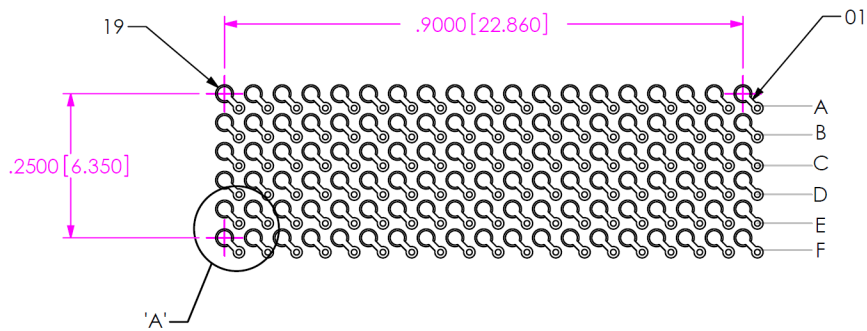

NOTE:
OUTER ROWS MAY NOT NEED VIAS - THIS IS LEFT TO
THE DISCRETION OF THE BOARD DESIGNER.

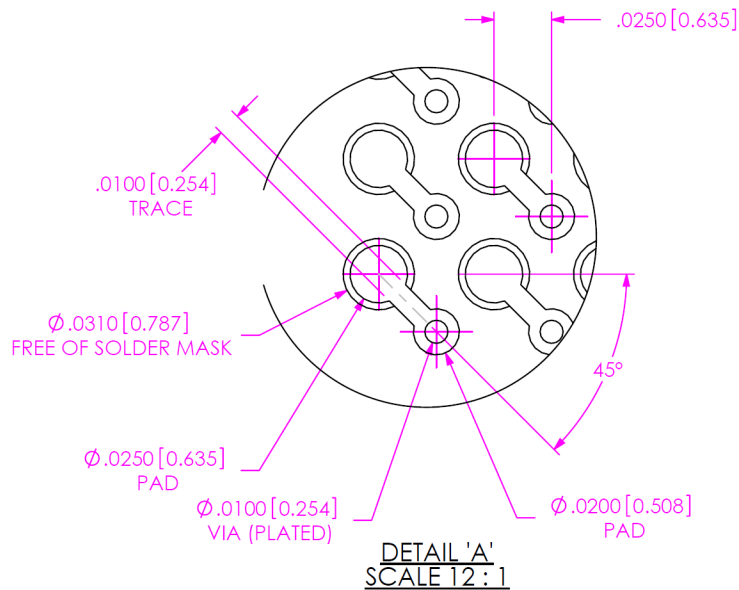

RECOMMENDED STENCIL LAYOUT
STENCIL TO BE .0060 [0.152] THICK

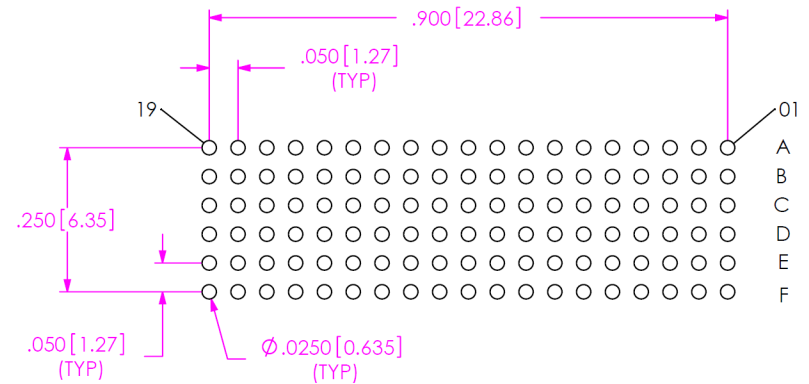

<p>PROPRIETARY NOTICE</p> <p>THIS DOCUMENT CONTAINS CONFIDENTIAL AND PROPRIETARY INFORMATION AND ALL DESIGN, MANUFACTURING, REPRODUCTION, USE, PATENT RIGHTS AND SALES RIGHTS ARE EXPRESSLY RESERVED BY SAMTEC, INC. THIS DOCUMENT SHALL NOT BE DISCLOSED, IN WHOLE OR PART, TO ANY UNAUTHORIZED PERSON OR ENTITY NOR REPRODUCED, TRANSFERRED OR INCORPORATED IN ANY OTHER PROJECT IN ANY MANNER WITHOUT THE EXPRESS WRITTEN CONSENT OF SAMTEC, INC.</p>	<p>DESCRIPTION:</p> <p>VITA 42 (LEADED) SOCKET ASSEMBLY</p>		
	<p>SHEET SCALE: 3:1</p>	<p>DWG. NO.</p> <p>ASP-103612-05</p>	
<p>F:\DWG\MISC\MKTG\ASP-103612-05-MKT.SLDDRW</p>		<p>BY: B. COOPER 12/08/06</p>	<p>SHEET 2 OF 2</p>