

DO NOT SCALE FROM THIS PRINT

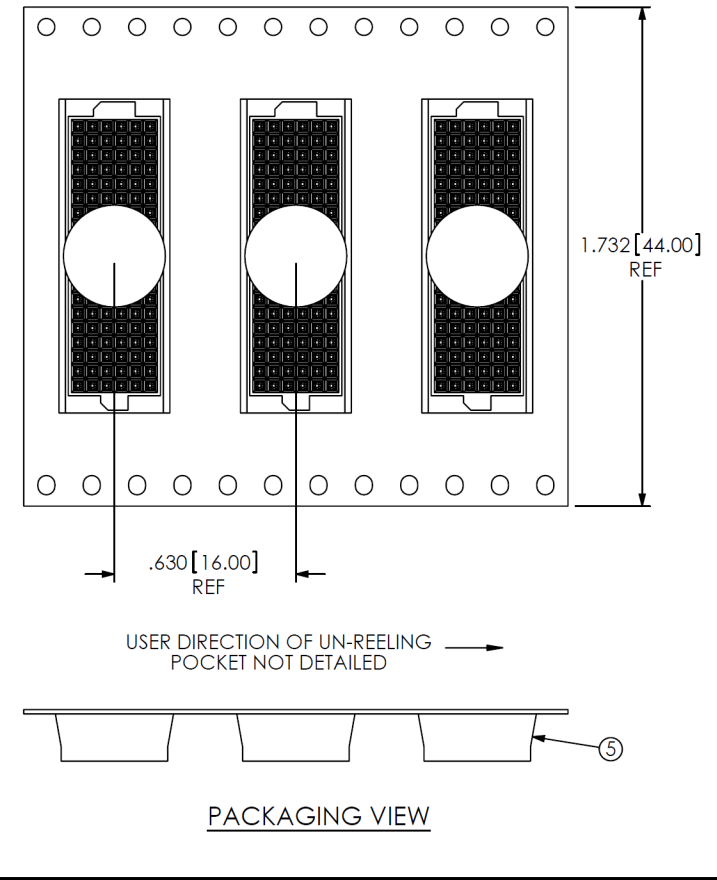

- NOTES:
1. USE LEAD FREE SOLDER BALLS & ASP-103597-01-B BODY FOR NON-STANDARD 19 POSITION.
 2. Ⓢ REPRESENTS A CRITICAL DIMENSION.
 3. BURR ALLOWANCE: .0005[0.013] MAX.
 4. MINIMUM PUSHOUT FORCE: .5 LB.
 5. MAXIMUM ALLOWABLE BOW: .002[0.05] INCH/INCH AFTER ASSEMBLY.
 6. NOTE DELETED.
 7. ONE REEL MINIMUM PLATING REQUIREMENT (85,000 CONTACTS PER REEL).
 8. ALL DIMS TO BE SYMMETRICAL ABOUT THE CENTERLINE WITHIN ±.001[0.03].
 9. MAXIMUM VARIATION BETWEEN SOLDERBALLS: .0025[0.064]
 10. REFER TO VISUAL INSPECTION BOARD FOR SOLDERBALL APPEARANCE CHECKS.
 11. THE DISTANCE FROM THE CENTER OF ANY SOLDERBALL TO THE CENTER OF ANY ADJACENT INNER PEG SHALL BE .025±.005[0.64±0.13].
 12. PARTS TO BE PACKAGED IN TAPE & REEL.
 13. CONTACT TO BE FLUSH: ±.002 [0.05].
 14. NO FLASH ALLOWED ON THE PIN TIPS.

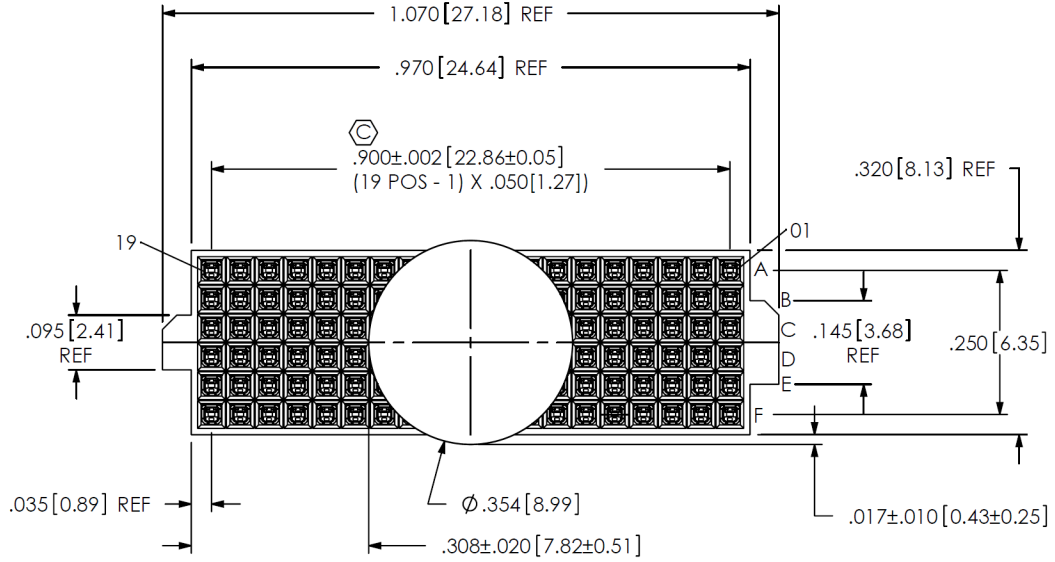

IN-PROCESS WITHOUT SOLDERBALLS
SEE NOTE 13

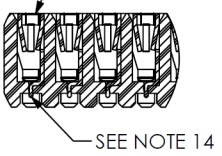

DETAIL 'B'
SCALE 4:1

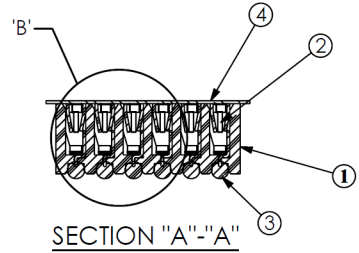
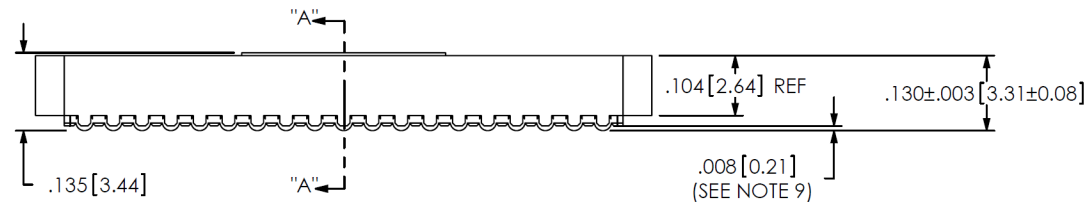

ITEM NO.	PART NUMBER	QUANTITY	MATERIAL
1	ASP-103597-01-B	1.0000	UL 94 V0, COLOR: BLACK
2	C-226-03-H	114.00	PHOS BRONZE, 521 HARD TEMPER
3	SDB-030-9653	114.00	96.5% Sn/3% Ag/.5% Cu
4	K-DOT-.354-.469-.005	1.0000	POLYIMIDE FILM
5	CT-ASP1132MS	.0015	CONDUCTIVE POLYMER

UNLESS OTHERWISE SPECIFIED, DIMENSIONS ARE IN INCHES.
TOLERANCES ARE:
DECIMALS ANGLES
.XX: ±.01 2°
.XXX: ±.005
.XXXX: ±.0020

PROPRIETARY NOTE
THIS DOCUMENT CONTAINS INFORMATION CONFIDENTIAL AND PROPRIETARY TO SAMTEC, INC. AND SHALL NOT BE REPRODUCED OR TRANSFERRED TO OTHER DOCUMENTS OR DISCLOSED TO OTHERS OR USED FOR ANY PURPOSE OTHER THAN THAT WHICH IT WAS OBTAINED WITHOUT THE EXPRESSED WRITTEN CONSENT OF SAMTEC, INC.



520 PARK EAST BLVD, NEW ALBANY, IN 47150
PHONE: 812-944-6733 FAX: 812-948-5047
e-Mail info@SAMTEC.com code 53322

DO NOT SCALE DRAWING SHEET SCALE: 3:1
PLATING:
CONTACT AREA: .000030 GOLD OVER .000050 NICKEL
REMAINDER: .000003 FLASH GOLD OVER .000050 NICKEL
F:\DWG\MISC\MKTG\ASP-103612-04-MKT.SLDDRW

DESCRIPTION:
VITA 42 lif (LEAD FREE) SOCKET ASSEMBLY
DWG. NO. ASP-103612-04
BY: RRC 10/13/06 SHEET 1 OF 2

RECOMMENDED BOARD LAYOUT

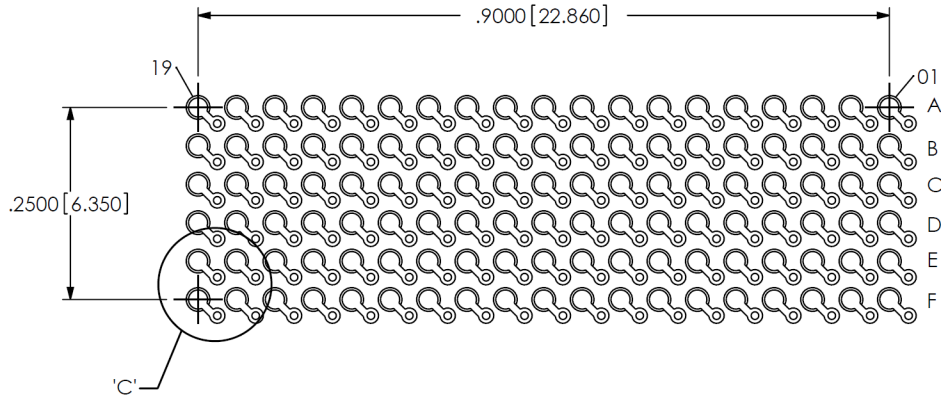

NOTE:
OUTER ROWS MAY NOT NEED VIAS - THIS IS LEFT TO
THE DISCRETION OF THE BOARD DESIGNER.

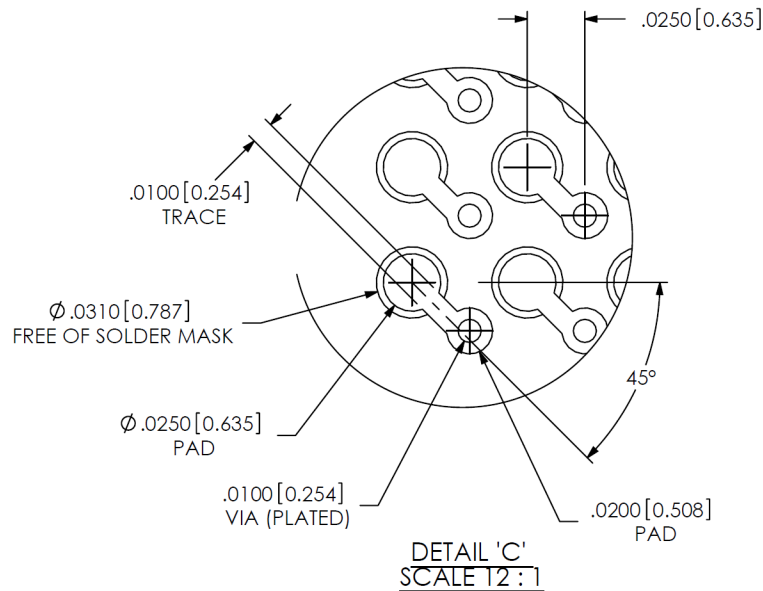

RECOMMENDED STENCIL LAYOUT
STENCIL TO BE .0060 [0.152] THICK

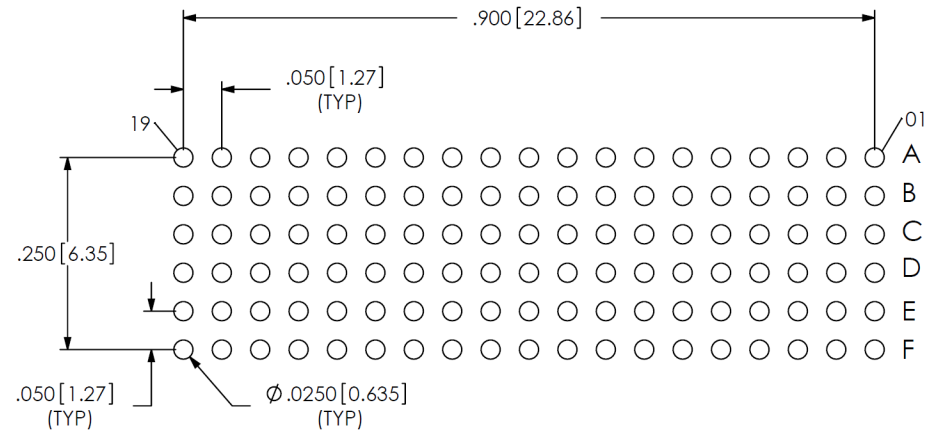

<p>PROPRIETARY NOTE THIS DOCUMENT CONTAINS INFORMATION CONFIDENTIAL AND PROPRIETARY TO SAMTEC, INC. AND SHALL NOT BE REPRODUCED OR TRANSFERRED TO OTHER DOCUMENTS OR DISCLOSED TO OTHERS OR USED FOR ANY PURPOSE OTHER THAN THAT WHICH IT WAS OBTAINED WITHOUT THE EXPRESSED WRITTEN CONSENT OF SAMTEC, INC.</p>	<p>samtec 520 PARK EAST BLVD, NEW ALBANY, IN 47150 PHONE: 812-944-6733 FAX: 812-948-5047 e-Mail: info@SAMTEC.com code 55322</p>		
	<p>DESCRIPTION: VITA 42 lif (LEAD FREE) SOCKET ASSEMBLY</p>	<p>DWG. NO. ASP-103612-04</p>	
<p>SHEET SCALE: 4:1</p>	<p>BY: RRC</p>	<p>10/13/06</p>	<p>SHEET 2 OF 2</p>