

NOTES

- MATERIALS:**
HOUSING-PBT 30%GF UL94V-0.
CONTACT-PHOSPHOR BRONZE, C5191R-H T=0.5mm.
- FLASH:** 0.25mm MAX.
- CAMBER:** 0.13mm MAX. **DEFORMATION:** NA.
WARP: 0.13mm MAX. **TWIST:** NA.

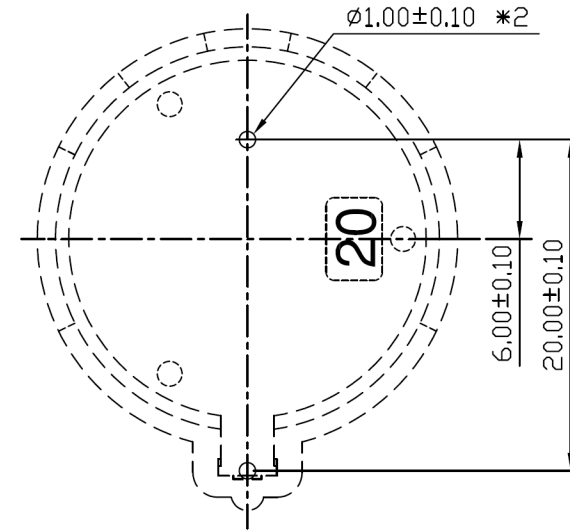

RECOMMEND PCB LAYOUT
COMPONENT SIDE

RoHS Compliant

the **vital**
component

DRAWING BY CY
CHECKED BY GENIUS
UNIT / mm SCALE 1 : 1
DATE
SIZE A4 PPROJECTION

TOLERANCES ARE

X. ±
.X ± 0.20
.XX ± 0.13
.XXX ± 0.05
ANG ±



ORDER INFORMATION

BH001-PBSR-LF

1 2 3

- 1 = Series
2 = Phospher Bronze Contacts
3 = RoHS (Lead Free)

DESCRIPTION: **BATTERY HOLDER ASS'Y**