

F SERIES CONNECTORS

F QUICK MALE, Crimp type F-101

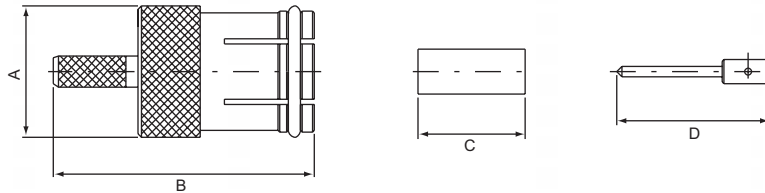

PART NO.	Ω	CABLE TYPE	A	B	C	D
F-101A	75	RG6U	11	21	12.7	/
F-101F		RG58U				
F-101G		RG59U				
F-101L	75	RG174U(316U)	11.5	23.2	9.5	13.6

F QUICK MALE, Twist-on type F-103

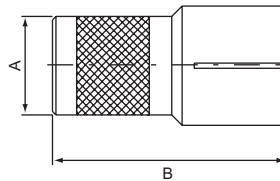

PART NO.	Ω	CABLE TYPE	A	B
F-103A	75	RG6U	8.8	20.5
F-103F		RG58U		
F-103G		RG59U		

F QUICK MALE, Twist-on type F-103/1

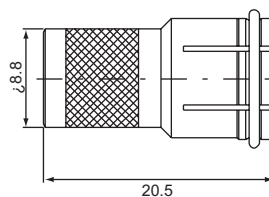

PART NO.	Ω	CABLE TYPE	A	B
F-103/1A	75	RG6U	8.8	20.5
F-103/1F		RG58U		
F-103/1G		RG59U		

F QUICK MALE, Attached grip ring
F-104

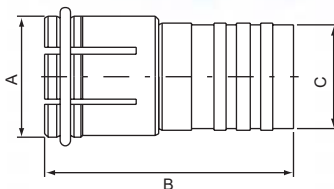

PART NO.	Ω	CABLE TYPE	A	B	C
F-104A	75	RG6U	10.7	22	9.2
F-104F		RG58U	10.8	22	8.5
F-104G		RG59U			

F MALE, Crimp type
F-111

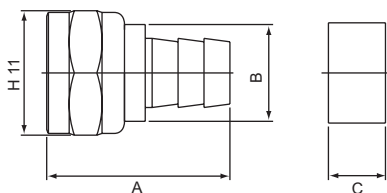

PART NO.	Ω	CABLE TYPE	A	B	C
F-111A	75	RG6U	16	8.5	5
F-111G		RG59U	16.4	8.5	5
F-111G-1			16.4	8.5	12.7

F MALE, Duplex crimp type
F-111D for RG11U

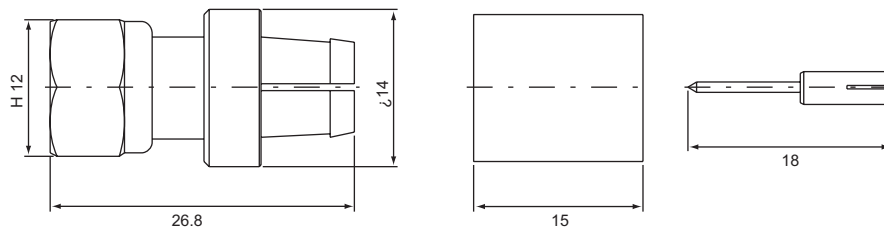

F MALE, Crimp type
F-111G-1E for RG59U

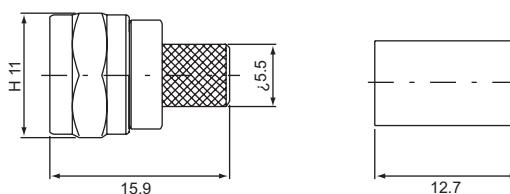

F MALE, Twist-on type
F-113A for RG6U

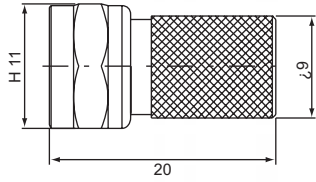

F-113F for RG58U

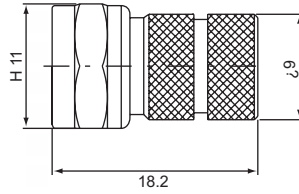

F-113G for RG59U

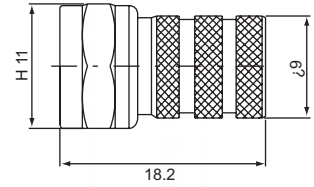

F MALE, Twist-on type
F-L113B/11U

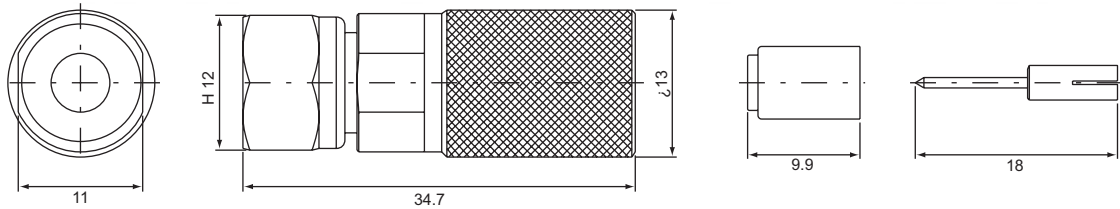

F MALE, Attached grip ring
F-114

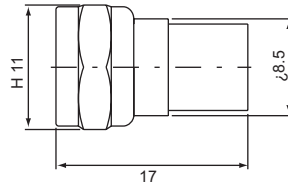

PART NO.	Ω	CABLE TYPE
F-114AF	75	RG58U
F-114AG		RG59U

F MALE, Attached grip ring
F-114

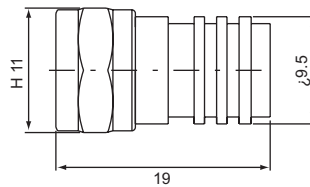

PART NO.	Ω	CABLE TYPE
F-114BA	75	RG6U
F-114BF		RG58U
F-114BG		RG59U

F MALE, Attached grip ring
F-114BB

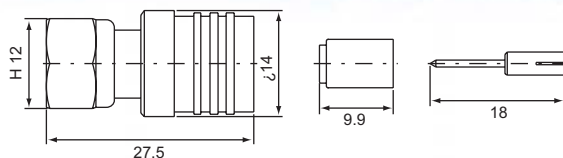

F MALE, Attached grip ring
F-114

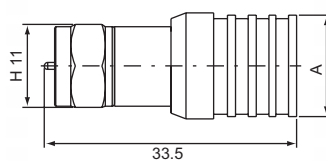

PART NO.	Ω	CABLE TYPE	A
F-114BB-2	75	RG213U	13.5
F-114BB-5			14

F MALE, Crimp type right angle
F-121

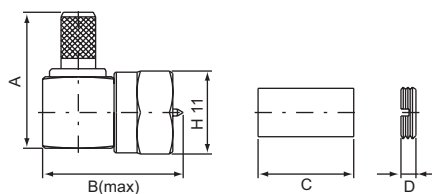

PART NO.	Ω	CABLE TYPE	A	B	C	D
F-121F	75	RG58U	18	18.6	12.7	2
F-121G		RG59U				
F-121L		RG174U(316U)	16.5	18.3	12.7	2

F MALE, Solder type Bulkhead receptacle
F-135

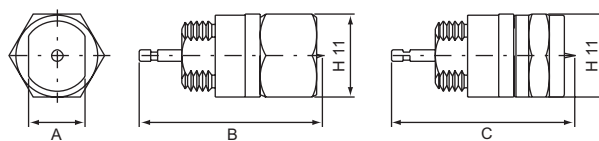

PART NO.	Ω	CABLE TYPE	A	B	C
F-135	75	WELDING SPOT	7.6	24.4	24.4
F-135-1			7.6		
F-135-2			7.4		

F MALE, Solder type Panel receptacle
F-145-SWP

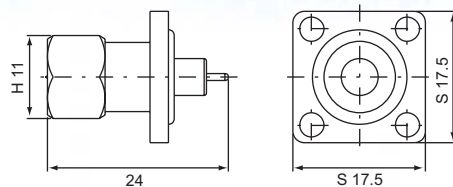

F FEMALE, Crimp type
F-211

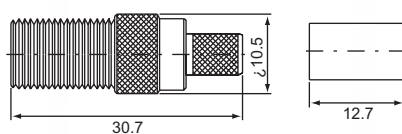

PART NO.	Ω	CABLE TYPE
F-211F	75	RG58U
F-211G		RG59U

F FEMALE, Crimp type
F-211L for RG174U(316U)

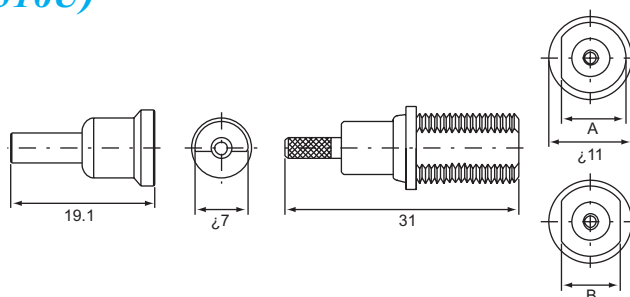

PART NO.	Ω	CABLE TYPE	A	B
F-211A[F,G,L,M,N]-D	75	RG6U[RG58U, RG59U, RG174U(316U), 178U, RG179U]	8.5	7.7
F-211A[F,G,L,M,N]-D/D				

F FEMALE, Attached grip ring
F-214

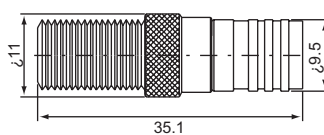

PART NO.	Ω	CABLE TYPE
F-214BA/9.5	75	RG6U
F-214BG/9.5		RG59U

**F FEMALE, Crimp type
Bulkhead receptacle
F-231L-2B-D
for RG179U**

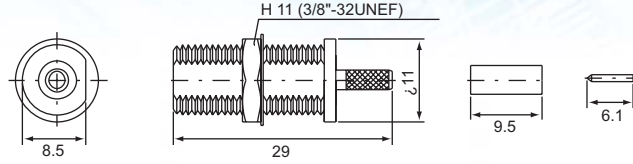

**F FEMALE, Solder type
Bulkhead receptacle
F-235**

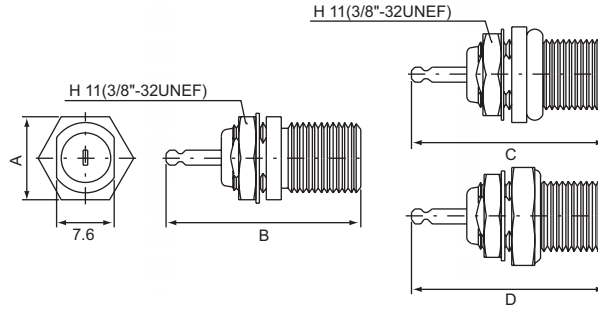

PART NO.	Ω	A	B	C	D	NOTE
F-235	75	11	26.1	/	/	WITH OUT NUT&WASHER
F-235NW						WITH NUT&WASHER
F-235-3B		11	19	/	/	WITH OUT NUT&WASHER
F-235NW-3B						WITH NUT&WASHER
F-235E		11	21.3	/	/	WITH OUT NUT&WASHER
F-235-HWP						WITH NUT&WASHER
F-235NW-HWP		12.7	/	/	25.8	WITH OUT NUT&WASHER
F-235HWP(F-61)						WITH NUT&WASHER
F-235NW-HWP(F-61)	13	/	/	/	26	WITH OUT NUT&WASHER
					WITH NUT&WASHER	

**F FEMALE, Crimp type
Panel receptacle
F-241L-HWP**

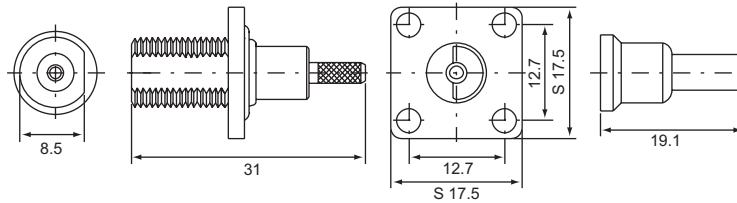

PART NO.	Ω	CABLE TYPE
F-241L-HWP	75	RG174U(316U, 179U, 187U, 188U)

**F FEMALE, Solder type
Panel receptacle
F-245-SWP**

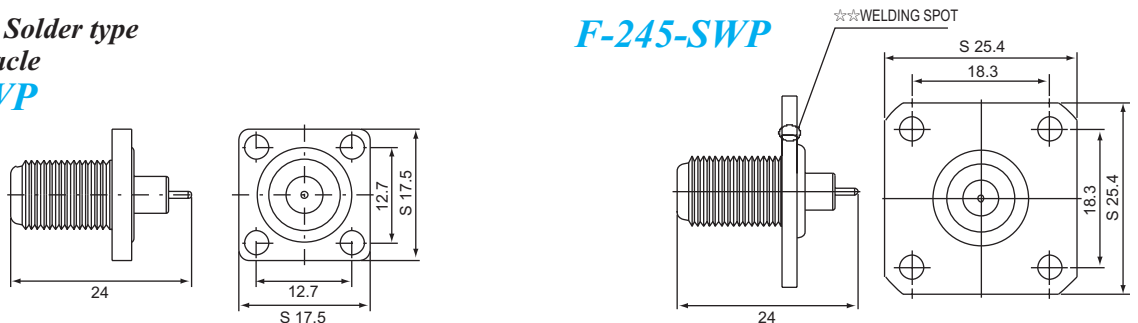

F FEMALE, Crimp type
F-411/1

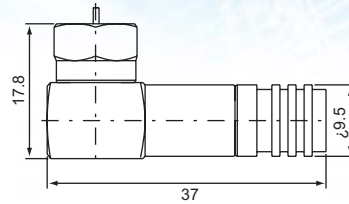

PART NO.	Ω	CABLE TYPE
F-411A/1	75	RG6U
F-411F/1		RG58U
F-411G/1		RG59U

F FEMALE, Solder type
F-B0215-1

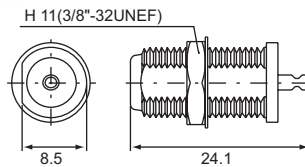

PART NO.	Ω	CABLE TYPE	NOTE
F-B0215-1	75	WELDING SPOT	WITHOUT NUT&WASHER
F-B0215NW-1			WITH NUT&WASHER

F FEMALE, Solder type
F-B215

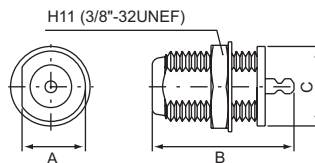

Ps. NW is NUT & WASHER

PART NO.	Ω	CABLE TYPE	A	B	C
F-B215	75	WELDING SPOT	8.4	18.5	10.5
F-B215NW					
F-B215/#1			8.4	18.8	10
F-B215/#1NW					
F-B215-1			8.5	19	10.5
F-B215NW-1					

F FEMALE, Solder type
F-B215-2B

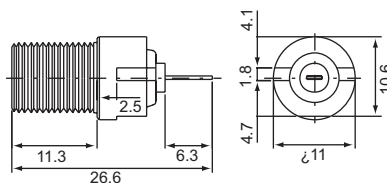

F FEMALE, Solder type
F-B215WP-3B

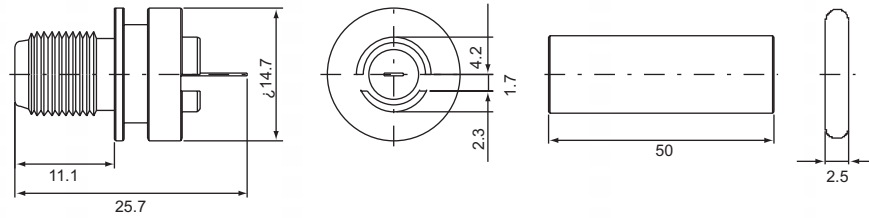

F FEMALE, Solder type
F-B215-4B

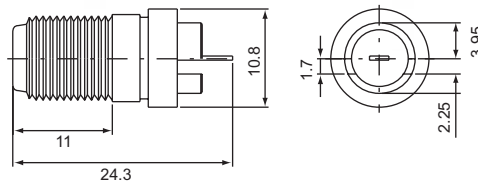

F FEMALE, Crimp type Bulkhead receptacle
F-B231-1B-NW

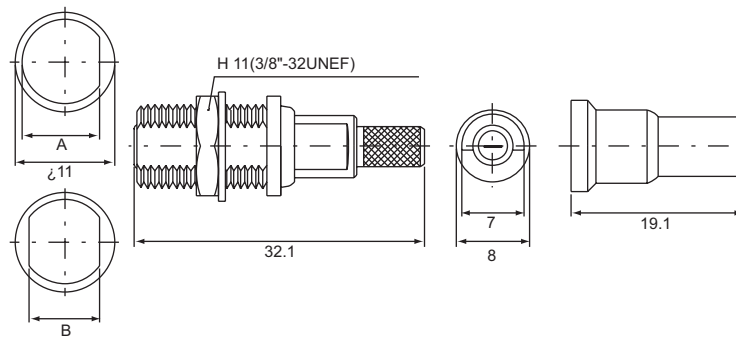

PART NO.	Ω	CABLE TYPE	A	B
F-231A[F,G,L,M,N]-1B-NW-D	75	RG6U[RG58U, RG59U, RG174U(316U), 178U, RG179U]	8.5	7.7
F-231A[F,G,L,M,N]-1B-NW-D/D				

F FEMALE, Solder type
F-F215
F-F215NW

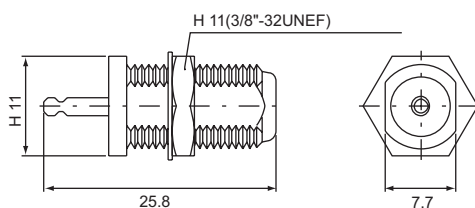

F MALE, Screw-on type
F-M112

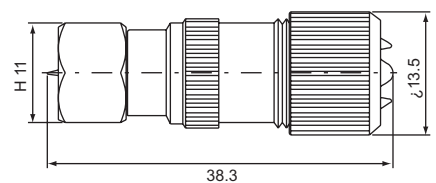

F QUICK MALE, Solder type
F-P105-1A PCB mount

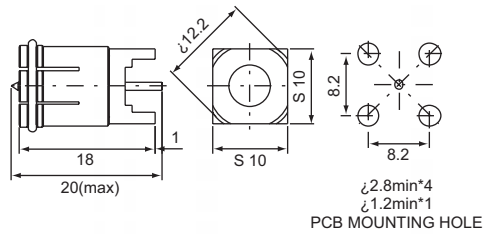

F QUICK MALE, Solder type
F-P105NW-1B

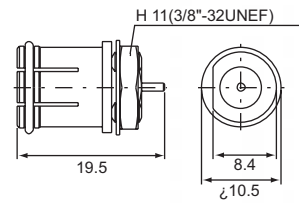

F MALE, Solder type
F-P115H PCB mount

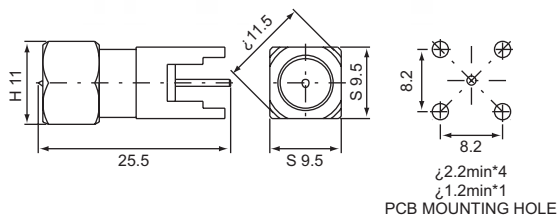

F FEMALE, PCB mount
F-P1215NW
F-P1215

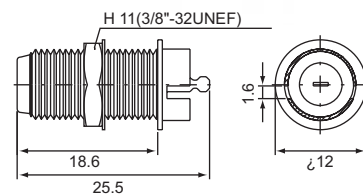

F QUICK MALE, Solder type
F-P125 PCB mount

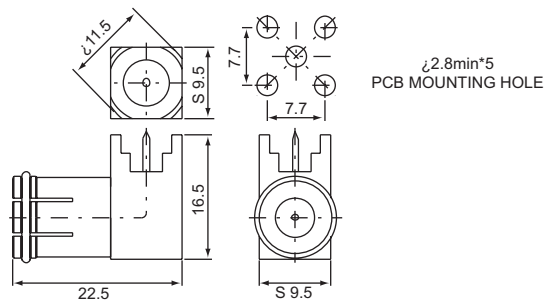

F FEMALE, Solder type
F-P215 PCB mount

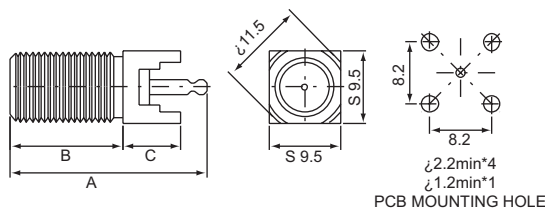

PART NO.	Ω	A	B	C
F-P215H	75	26.2	13	12.5
F-P215L		26.2	15	7.6
F-P215S/1		27.8	20.2	7.6
F-P215SS		22.5	15	7.5
F-P2151		21	13	6.5

F FEMALE, PCB mount
F-P215-1A

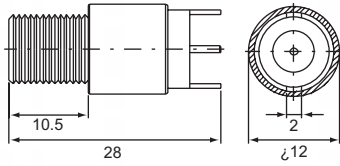

F FEMALE, PCB mount
F-P215H/20

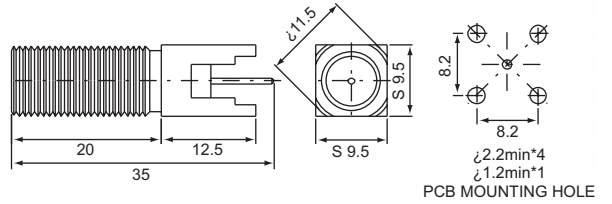

F FEMALE, PCB mount
F-P215L-1A

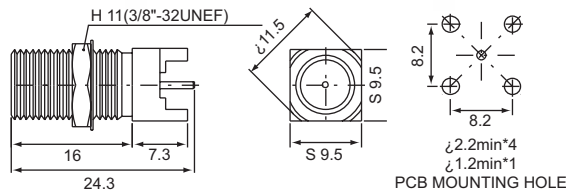

F MALE, PCB mount
F-P2215

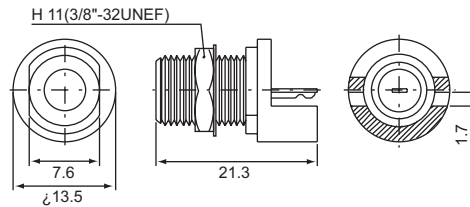

PART NO.	Ω	NOTE
F-P2215	75	WITHOUT NUT&WASHER
F-P2215NW		WITH NUT& WASHER

F MALE, PCB mount
F-P2215L

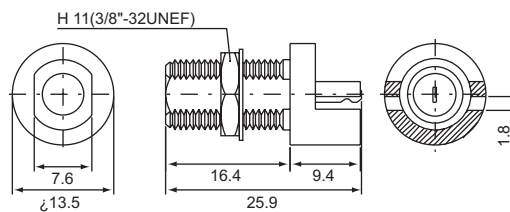

PART NO.	Ω	NOTE
F-P2215L	75	WITHOUT NUT&WASHER
F-P2215L-NW		WITH NUT& WASHER

F FEMALE, Solder type
F-P225 PCB mount

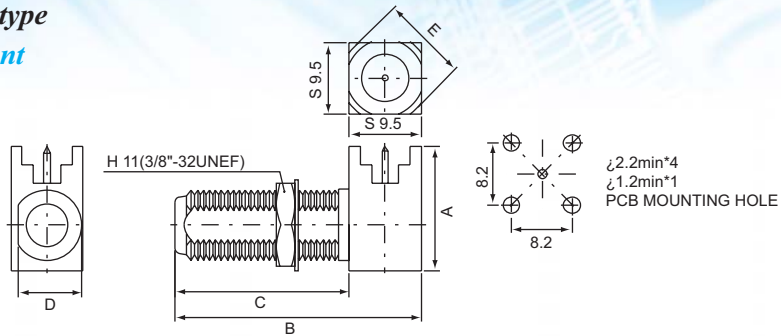

PART NO.	Ω	A	B	C	D	E	NOTE
F-P225	75	16.5	32.5	23	8.5	11.6	WITH OUT NUT&WASHER
F-P2255							WITH NUT&WASHER
F-P225/24		16.5	24	14.5	8.5	11.6	WITH OUT NUT&WASHER
F-P225/28							WITH NUT&WASHER
F-P225NW/28		16.5	28	18.5	8.5	11.8	WITH OUT NUT&WASHER
F-P225NW/28-1A							WITH NUT&WASHER
F-P225/28-1D		16.5	28	18.5	8.5	11.6	WITH OUT NUT&WASHER
F-P225NW/28-1D							WITH NUT&WASHER
F-P225/35.8		14.2	35.8	26.3	8.5	11.6	WITH OUT NUT&WASHER
F-P225NW/35.8							WITH NUT&WASHER
F-P225/36.25		16.5	45.75	36.25	8.5	11.8	WITH OUT NUT&WASHER
F-P225NW/36.25							WITH NUT&WASHER

F FEMALE, Solder type
F-P225-3A PCB mount

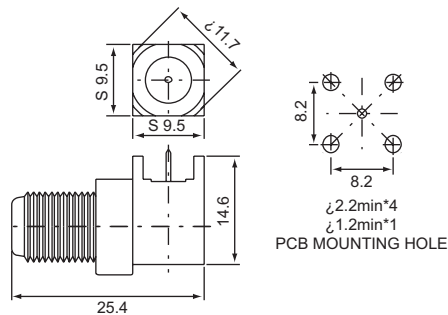

F FEMALE, Solder type PCB mount
F-P225SH

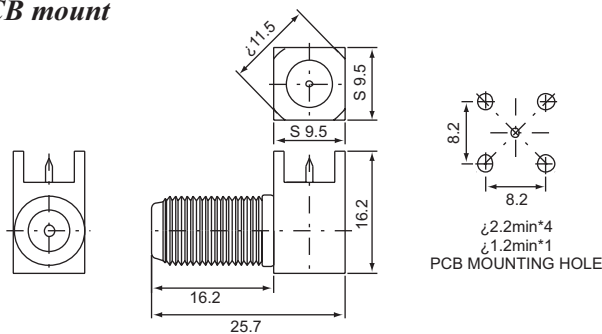

PART NO.	Ω	A	B
F-P225SH	75	25.5	16
F-P225SH/22		22	12.5

F FEMALE, PCB mount
F-P225SH/22-1

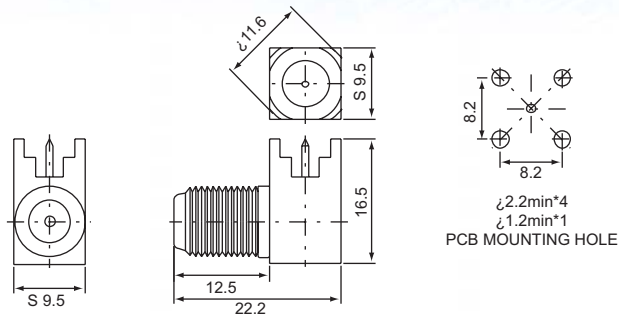

F FEMALE, PCB mount
F-P2253-1A

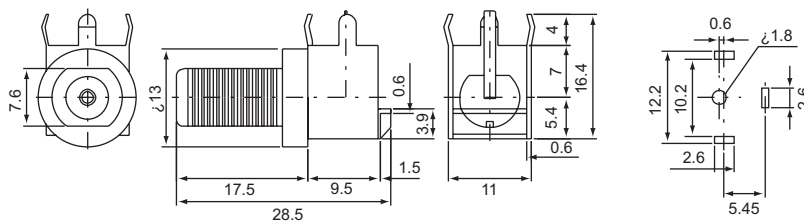

F FEMALE, PCB mount
F-P2253-2A

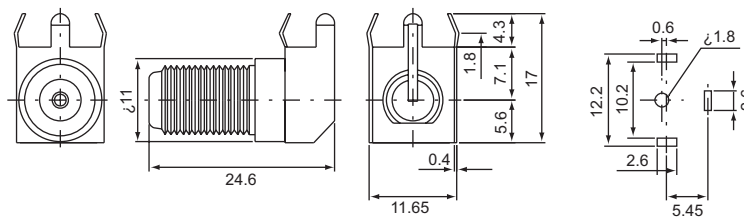

F FEMALE, Solder type
F-P245 panel receptacle

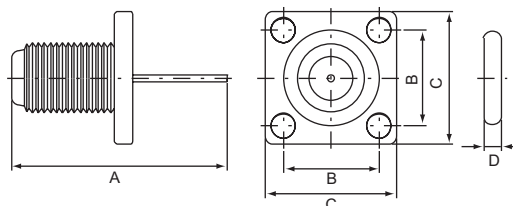

PART NO.	Ω	A	B	C	D
F-P245-25.4	75	31.9	18.3	25.4	
F-P245SWP-1C		28.6	12.7	17.5	1.8
F-P245-2C		31	12.7	17.5	

F FEMALE, PCB mount
F-P225SH/22-1

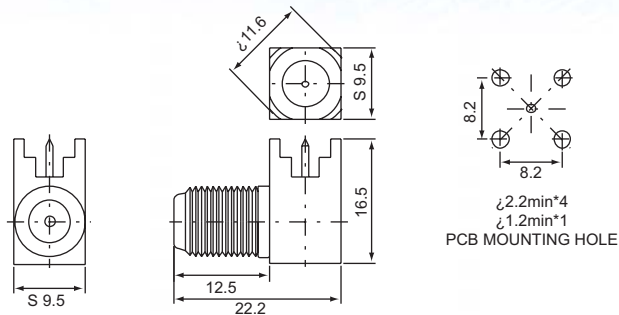

F FEMALE, PCB mount
F-P2253-1A

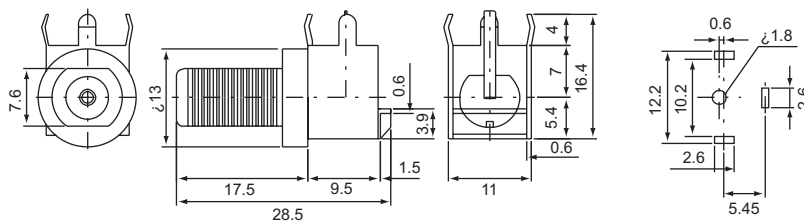

F FEMALE, PCB mount
F-P2253-2A

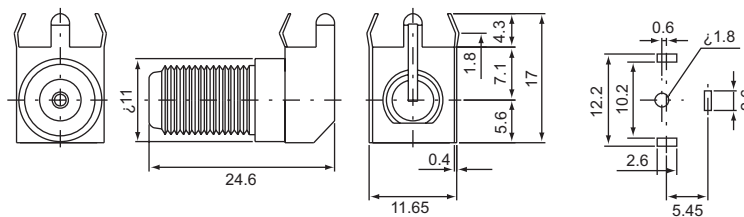

F FEMALE, Solder type
F-P245 panel receptacle

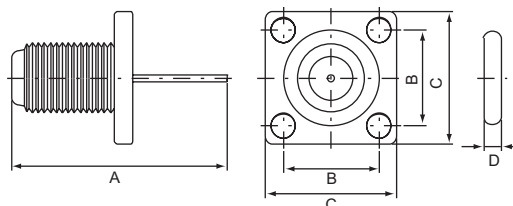

PART NO.	Ω	A	B	C	D
F-P245-25.4	75	31.9	18.3	25.4	
F-P245SWP-1C		28.6	12.7	17.5	1.8
F-P245-2C		31	12.7	17.5	

F FEMALE, Solder type
F-S215

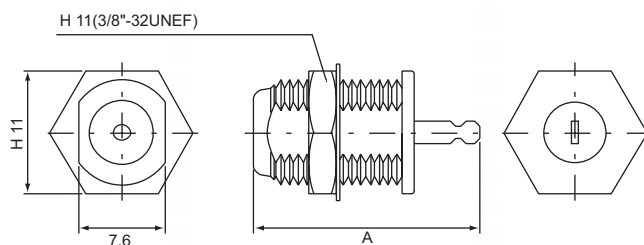

PART NO.	Ω	A
F-S215	75	20.5
F-S215NW		
F-S215-2	75	18.5
F-S215NW-2		

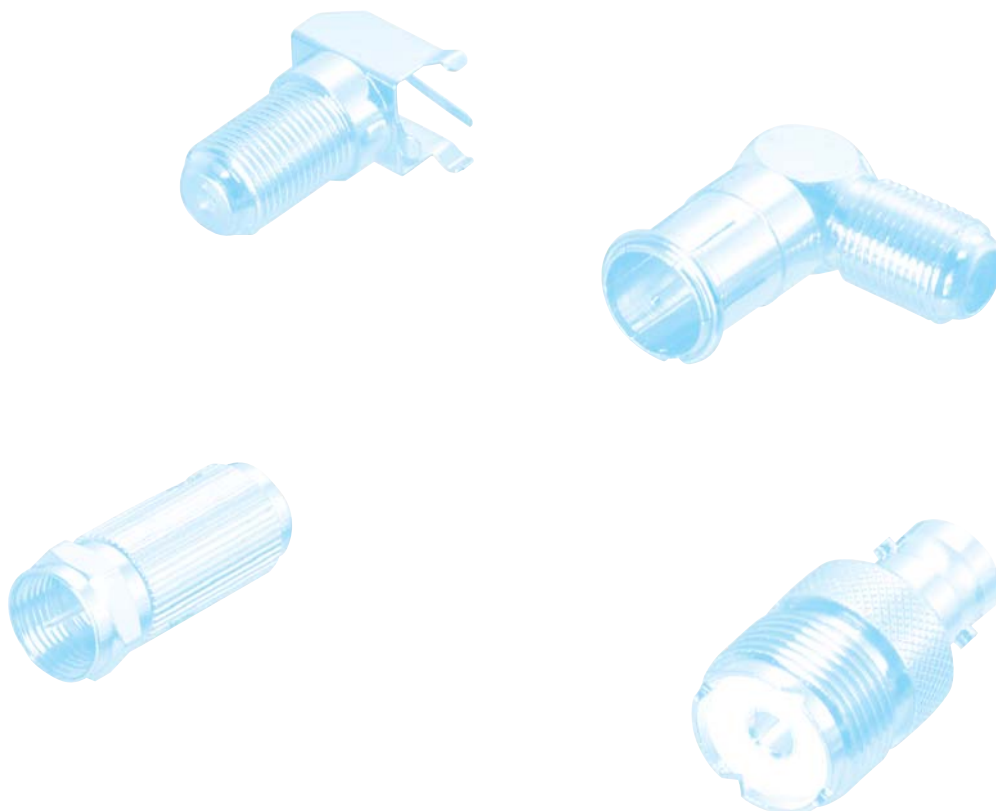

F SERIES CONNECTORS

F QUICK MALE, Crimp type F-101

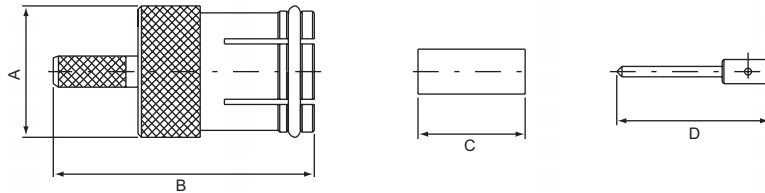

PART NO.	Ω	CABLE TYPE	A	B	C	D
F-101A	75	RG6U	11	21	12.7	/
F-101F		RG58U				
F-101G		RG59U				
F-101L	75	RG174U(316U)	11.5	23.2	9.5	13.6

F QUICK MALE, Twist-on type F-103

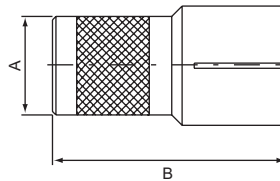

PART NO.	Ω	CABLE TYPE	A	B
F-103A	75	RG6U	8.8	20.5
F-103F		RG58U		
F-103G		RG59U		

F QUICK MALE, Twist-on type F-103/1

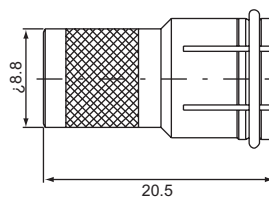

PART NO.	Ω	CABLE TYPE	A	B
F-103/1A	75	RG6U	8.8	20.5
F-103/1F		RG58U		
F-103/1G		RG59U		

F QUICK MALE, Attached grip ring
F-104

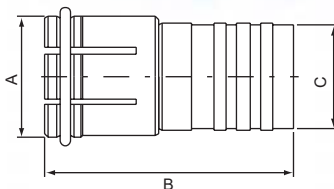

PART NO.	Ω	CABLE TYPE	A	B	C
F-104A	75	RG6U	10.7	22	9.2
F-104F		RG58U	10.8	22	8.5
F-104G		RG59U			

F MALE, Crimp type
F-111

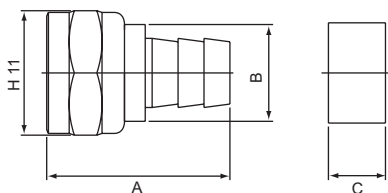

PART NO.	Ω	CABLE TYPE	A	B	C
F-111A	75	RG6U	16	8.5	5
F-111G		RG59U	16.4	8.5	5
F-111G-1			16.4	8.5	12.7

F MALE, Duplex crimp type
F-111D for RG11U

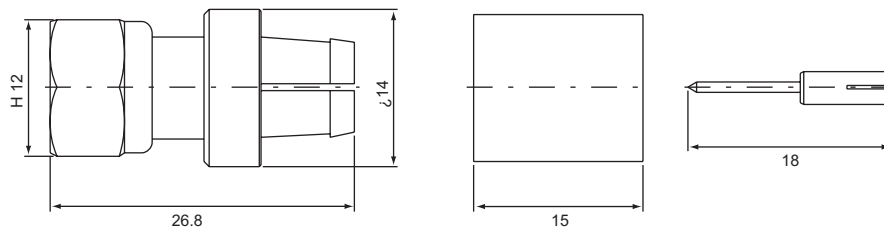

F MALE, Crimp type
F-111G-1E for RG59U

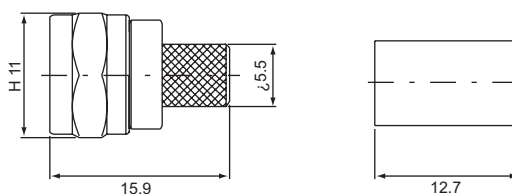

F MALE, Twist-on type
F-113A for RG6U

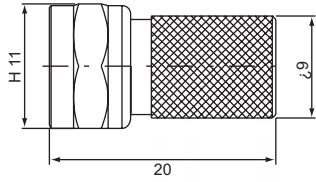

F-113F for RG58U

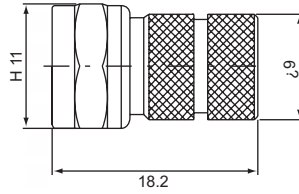

F-113G for RG59U

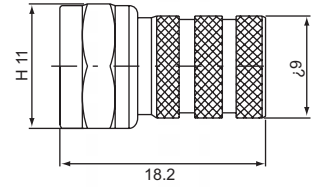

F MALE, Twist-on type
F-L113B/11U

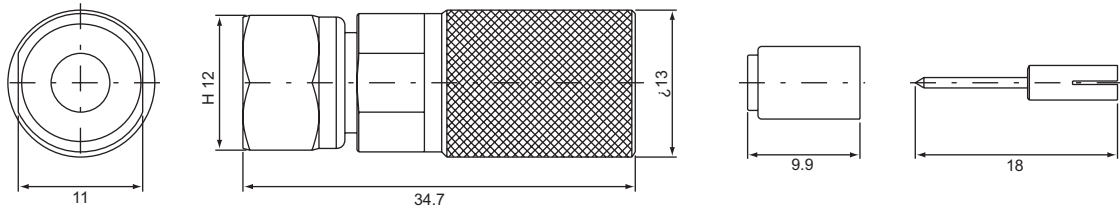

F MALE, Attached grip ring
F-114

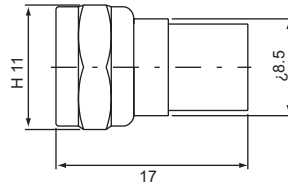

PART NO.	Ω	CABLE TYPE
F-114AF	75	RG58U
F-114AG		RG59U

F MALE, Attached grip ring
F-114

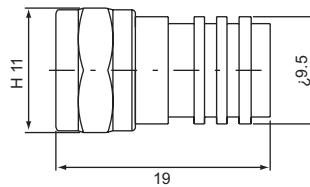

PART NO.	Ω	CABLE TYPE
F-114BA	75	RG6U
F-114BF		RG58U
F-114BG		RG59U