

DESIGNED & DIMENSIONED
IN MILLIMETERS

DCA-10-XX

SIZE
-10

STYLE

-01: PANEL MOUNT DUST CAP
-02: CABLE DUST CAP

NOT RELEASED
FOR PRODUCTION

USE FOR QUOTING, PRELIMINARY
DESIGN, PROTOTYPING AND
INFORMATIONAL PURPOSES ONLY

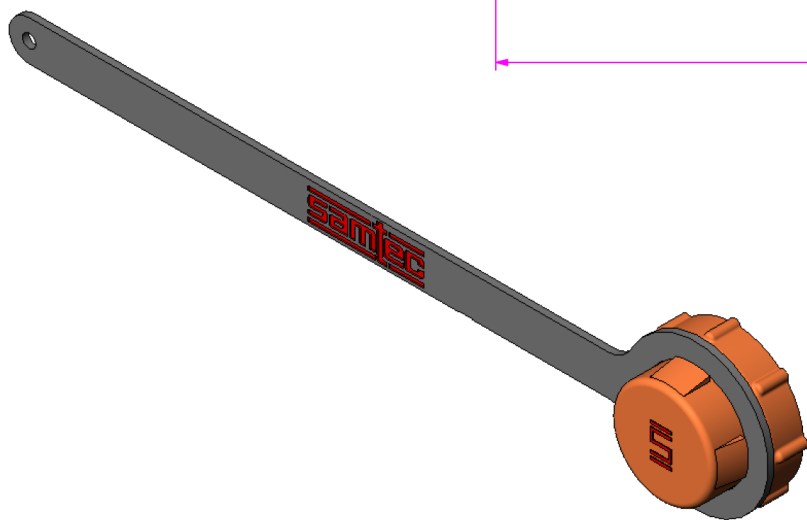
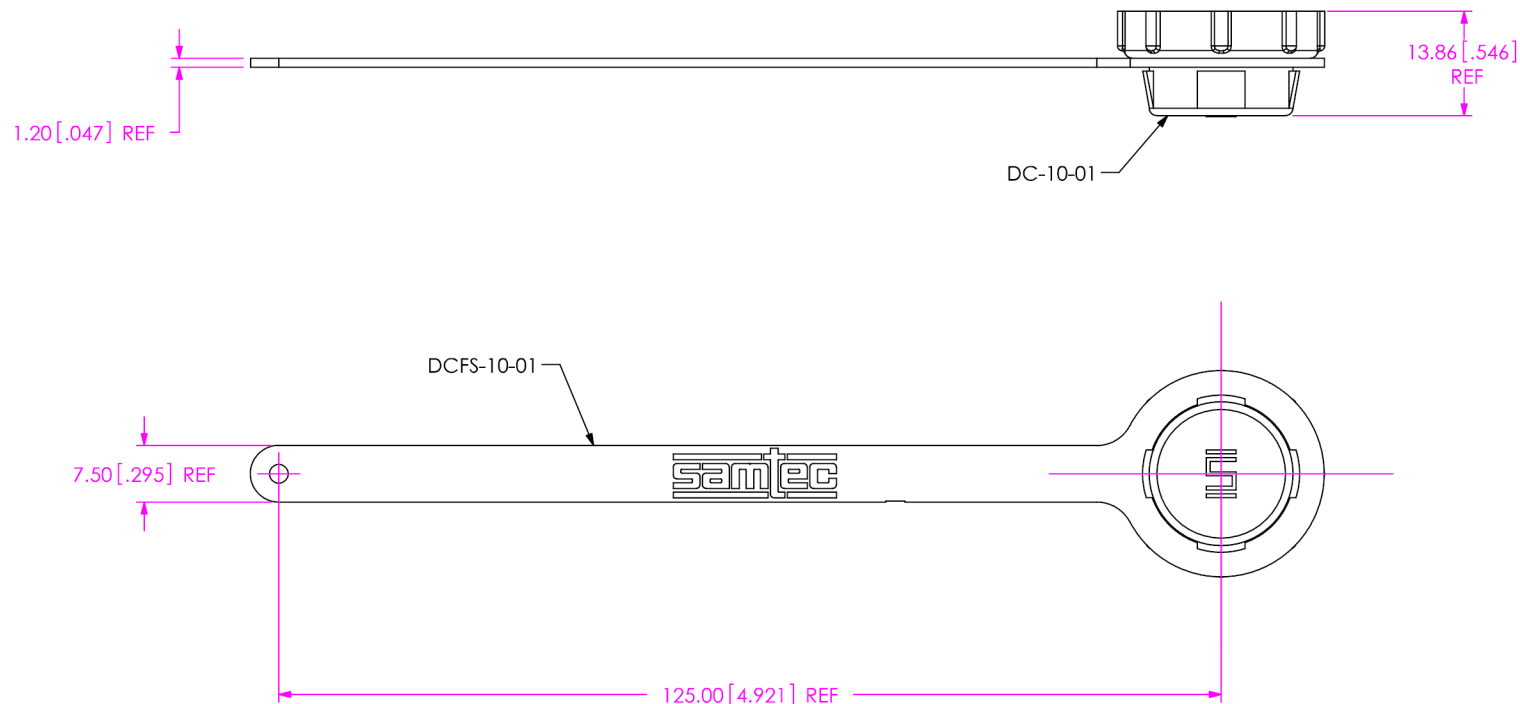

FIG. 1
DCA-10-01 SHOWN



NOTES:

1. Ⓢ REPRESENTS A CRITICAL DIMENSION.
2. VENDOR TO ASSEMBLE PARTS.
3. COMPONENTS OF SUB-ASSEMBLY TO BE INSPECTED USING COMPONENT PRINTS.

UNLESS OTHERWISE SPECIFIED,
DIMENSIONS ARE IN MILLIMETERS.
TOLERANCES ARE:
DECIMALS ANGLES
.X: ±0.3 [.01] 2°
.XX: ±0.13 [.005]
.XXX: ±0.051 [.0020]

PROPRIETARY NOTE

THIS DOCUMENT CONTAINS INFORMATION
CONFIDENTIAL AND PROPRIETARY TO
SAMTEC, INC. AND SHALL NOT BE REPRODUCED
OR TRANSFERRED TO OTHER DOCUMENTS OR
DISCLOSED TO OTHERS OR USED FOR ANY
PURPOSE OTHER THAN THAT WHICH IT WAS
OBTAINED WITHOUT THE EXPRESSED WRITTEN
CONSENT OF SAMTEC, INC.

SAMTEC

e-Mail: askjim@toby.co.uk

CODE: 55322

MATERIAL: DO NOT SCALE DRAWING
STRAP: LDPE
CAP: PA66
O-RING: SILICONE



DESCRIPTION:
DUST CAP ASSEMBLY FOR SIZE 10 ACCLIMATE

DWG. NO. **DCA-10-XX**

BY: LENNY K 4/26/06

SHEET 1 OF 2

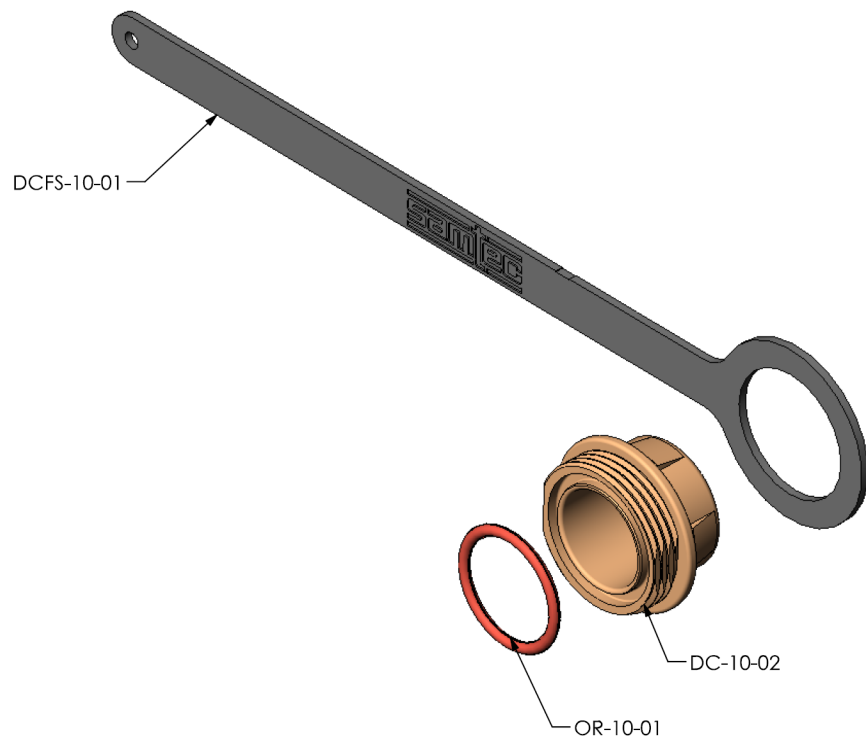
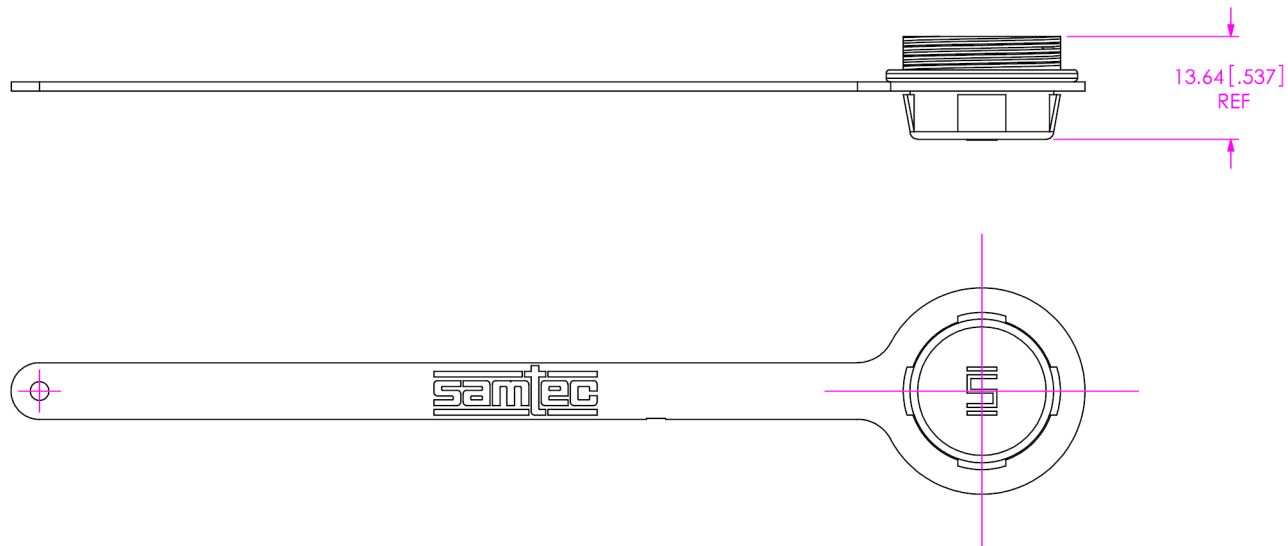

FIG. 2
DCA-10-02 SHOWN
(SAME AS FIG. 1, UNLESS OTHERWISE STATED)



SAMTEC

e-Mail: askjim@toby.co.uk CODE: 55322

DESCRIPTION:
DUST CAP ASSEMBLY FOR SIZE 10 ACCLIMATE

DWG. NO. **DCA-10-XX**

BY: LENNY K 4/26/06 SHEET 2 OF 2

PROPRIETARY NOTE
THIS DOCUMENT CONTAINS INFORMATION CONFIDENTIAL AND PROPRIETARY TO SAMTEC, INC. AND SHALL NOT BE REPRODUCED OR TRANSFERRED TO OTHER DOCUMENTS OR DISCLOSED TO OTHERS OR USED FOR ANY PURPOSE OTHER THAN THAT WHICH IT WAS OBTAINED WITHOUT THE EXPRESSED WRITTEN CONSENT OF SAMTEC, INC.

DO NOT SCALE DRAWING

SHEET SCALE: 1:1